

## HoSta - Multifunctional door

> Installation, operating and maintenance manual



## Table of contents

<b>1</b>	<b>Preface</b> .....	<b>5</b>
<b>2</b>	<b>Technical data</b> .....	<b>6</b>
<b>3</b>	<b>Guidelines and standards</b> .....	<b>7</b>
<b>4</b>	<b>Generally applicable information and safety notes</b> .....	<b>8</b>
4.1	Symbols and safety notes .....	8
4.2	Safety notes .....	8
4.3	Professional handling .....	9
4.4	Hazard warnings .....	10
<b>5</b>	<b>Basic instructions</b> .....	<b>11</b>
5.1	General.....	11
5.2	Competent persons .....	11
5.3	Laypersons .....	11
5.4	Intended use.....	11
5.5	Operator's obligations .....	12
5.6	Obligations of the user .....	12
5.7	Warranty and liability .....	12
5.8	Safety measures for assembly, commissioning and maintenance .....	13
5.9	Residual risk analysis.....	13
5.10	Packaging.....	13
5.11	Disposal.....	13
<b>6</b>	<b>Assembly and installation</b> .....	<b>14</b>
6.1	Safety notes for assembly .....	14
6.2	Electrical connection .....	15
6.3	Fasteners .....	15
6.4	Assembly requirements.....	17
6.4.1	Checking delivery for completeness .....	17
6.4.2	Checking the wall opening .....	17
6.4.3	Overview of anchor positions and screw connections .....	17
6.5	Door installation.....	18
6.5.1	Assembling the frame parts .....	18
6.6	Stages of assembly .....	19
6.6.1	Raising and fixing the frame .....	19
6.6.2	Corner frame with invisible fixing (screw mounting) .....	20
6.6.3	Corner frame with invisible fixing (welding assembly) .....	21
6.6.4	Block frame .....	22
6.6.5	Block frame in 2-parts with invisible fixing .....	23
6.6.6	Plug-in frame with invisible fixing .....	24
6.6.7	Floor connection .....	25
6.7	Hinge installation .....	26
6.7.1	Hinge KOF 2-parts .....	26
6.7.1.1	Components.....	26
6.7.1.2	Hinge installation.....	27
6.7.1.3	Mounting accessories .....	27
6.7.2	Hinge KOF 3-parts .....	28
6.7.2.1	Components.....	28
6.7.2.2	Hinge installation.....	29
6.7.2.3	Mounting accessories .....	29

6.7.3	KOH-3D - Stainless steel door hinge.....	30
6.7.3.1	Components.....	30
6.7.3.2	Hinge installation.....	31
6.7.3.3	Mounting accessories .....	31
6.7.4	3D-Hinge.....	33
6.7.4.1	Assembly tool.....	33
6.7.4.2	Assembly of the hinges.....	33
6.7.4.3	Replacing the hinges .....	33
6.7.5	Hinge XXL.....	34
6.7.5.1	Components.....	34
6.7.5.2	Hinge installation.....	35
6.8	Adjusting the door hinges.....	36
6.8.1	Type KOF 2-parts and 3-parts .....	37
6.8.2	Type KOH-3D .....	38
6.8.3	Typ 3D .....	39
6.9	Frame grouting.....	40
6.10	Special performance characteristics .....	41
6.10.1	Air tightness / Water tightness / Wind load resistance .....	41
6.10.2	Sound protection.....	41
6.10.3	Burglary resistance .....	41
6.10.4	Smoke protection .....	41
6.10.5	Fire protection .....	41
6.11	Assembly of accessories.....	42
6.12	Frame sealing obligatory for outdoor use .....	43
<b>7</b>	<b>Operation.....</b>	<b>46</b>
7.1	Commissioning.....	46
7.2	Decommissioning .....	46
<b>8</b>	<b>Maintenance and Servicing .....</b>	<b>47</b>
8.1	General Information .....	47
8.2	Servicing.....	47
8.3	Monthly checks.....	48
8.4	Yearly inspection and maintenance .....	48
8.5	Safety regulations.....	48
8.6	Recommissioning .....	49
8.7	Checklist for maintenance, commissioning and acceptance .....	50
<b>9</b>	<b>Troubleshooting .....</b>	<b>51</b>
<b>10</b>	<b>Cleaning and care instructions.....</b>	<b>52</b>
10.1	General information.....	52
10.2	Steel .....	52
10.3	Stainless steel .....	52
10.4	Initial on-site cleaning.....	54
10.5	Glazing .....	55
10.5.1	Inspection.....	55
10.5.2	Maintenance and care .....	55
10.5.3	Cleaning.....	55

---

10.6	Louvre grid .....	56
10.6.1	Maintenance and care .....	56
10.6.2	Cleaning.....	56
10.7	Fittings, locks.....	56
10.8	Seals .....	56
<b>11</b>	<b>Replacement parts / Special tools .....</b>	<b>57</b>
<b>12</b>	<b>Certificate of compliance.....</b>	<b>58</b>
<b>13</b>	<b>Remarks .....</b>	<b>59</b>

# 1 Preface

Dear customers,

This installation, operating and maintenance manual for the Hodapp Multifunctional door (HoSta):

- **Safety notes**
- **Assembly**
- **Commissioning**
- **Care**
- **Maintenance**

The manufacturer accepts no liability for damage caused by incorrect operation or connection, non-compliance with the operating instructions or lack of maintenance or care.

Our instruction manual is updated on a regular basis. Your suggestions for improvement help us create an instruction manual with improved user-friendliness.

Should you have any suggestions for improvement, please get in touch with us.

## **Storage:**

This instruction manual contains important information for a safe, proper and economical use of the system. Always keep the instruction manual handy for reference.

## **Imprint:**

<b>Manufacturer:</b>	Hodapp GmbH & Co. KG Stahltürenbau & CNC-Blechtechnik Grossweierer Strasse 77 77855 Achern Germany
<b>Telephone no.:</b>	+49(7841) 6006-0
<b>Fax no.:</b>	+49(7841) 6006-10
<b>Email:</b>	info@hodapp.de
<b>Document type:</b>	Installation, operating and maintenance manual
<b>Created on:</b>	11.02.2016
<b>Type of product:</b>	Hodapp Multifunctional Door (HoSta)

## 2 Technical data

The product data listed here shows all possibilities of the product, the order-related versions may differ.

Manufacturer:	HODAPP
Name:	HoSta – Multifunctional Door
Air tightness:	≤ Class 4 [EN 12207:2016]
Watertightness:	≤ Class 9A [EN 12208:1999]
Wind load:	≤ Class C5 (up to 6000 Pa) [EN 12210:2016]
Sound protection:	≤ 60 dB [EN ISO 717-1:2013]
Burglary resistance:	≤ RC-4 [EN 1627]
Fire-resistance class:	EI <sub>2</sub> -30 / EI <sub>2</sub> -60 / EI <sub>2</sub> -90 / EI <sub>2</sub> -120 [EN 13501-2]
IP protection:	≤ IP 66
Bullet resistance	FB 4 [EN 1522]
Thermal transmittance:	[ISO 10077-1:2016]
Single-leaf:	without glazing: 1,5 W/(m <sup>2</sup> K) with glazing 1,7 W/(m <sup>2</sup> K)
Double-leaf:	without glazing: 1,5 W/(m <sup>2</sup> K) with glazing 1,8 W/(m <sup>2</sup> K)
Opening direction:	opening to the left / opening to the right
Size range (structural opening):	
Single leaf:	Width: 500 – 1800 mm Height: 500 – 6000 mm
Double-leaf:	Width: 1000 – 5000 mm Height: 500 – 6000 mm
Door leaf thickness:	69 mm
Material:	Stainless steel 316 L / 316 Ti (1.4404 / 1.4571), 304 L (1.4307) Steel DC01+ZE1, DX51D+Z
Surface:	Steel with primer / Steel painted Stainless steel mill finish / Stainless steel painted
Fitting:	Standard fitting
Frame:	System Hodapp
Mounting on:	All permitted wall types

## 3 Guidelines and standards

### Normative references

This document may contain references to directives and international standards. For dated references, subsequent changes or modifications to this publication do not apply. For non-dated references, the most current version of the document to which the reference refers shall apply. The members of ISO and IEC maintain directories of current international standards.

- 305/2011 Construction Products Regulation
- EN 14351-1:2016 Windows and doors - Product standard, performance characteristics  
Part 1: Windows and external pedestrian door sets

### Quality standards

- ISO 9001:2015 Quality management systems - Requirements
- EN 1090-1:2009 Execution of steel structures and aluminium structures
- ISO 3834-2:2005 Quality requirements for fusion welding of metallic materials

## 4 Generally applicable information and safety notes

Please pay attention to the information and safety notes provided below.

### 4.1 Symbols and safety notes



This symbol denotes an imminent danger to the life and health of persons. By ignoring these instructions you may endanger the life and limb of the user, and cause serious detriment to health



This symbol gives important instructions on the proper use of the gate. If these instructions are not observed, it may cause the gate to malfunction.



This symbol indicates the exclusion of the manufacturer's liability in case of mistakes or neglect by the operator or user.



Special information regarding loss prevention. Advice that simplifies work and enables economical operation.



This symbol indicates the proper recycling of packaging material and disused components (separated as metals, plastics, etc.).

### 4.2 Safety notes



The safety notes in these instruction manual must be followed at all times!

#### Work safety

This chapter describes the safety procedures which must be taken into account in regard to door and gate systems.



This chapter does not replace any regulations, but must be understood as a complement to the generally applicable regulations on occupational safety and health.

- Any operation affecting the safety of the system and the safety and health protection of individuals should be prohibited.
- Any person in the user's company who is involved with the assembly, disassembly and reassembly, commissioning, operation and servicing (inspection, maintenance, repair) of the system must have read and understood the complete instruction manual, especially the **Chapter 4**. It is recommended that the user requests a written acknowledgement of this.



The door systems are designed exclusively for use in accordance with the specifications contained in **Chapter 2**. Any other use is considered improper. The manufacturer is not liable for any damage resulting from this; the risk is solely borne by the user.



- Intended use also includes compliance with the assembly, commissioning, operation, servicing, disassembly and disposal conditions specified here by the manufacturer.
- Make sure that connections are dry and free of dirt.
- All access ways and passages in the installation must be unobstructed and fully accessible for inspection and maintenance purposes.
- When operating these systems you have to also observe the national/regional safety and accident prevention regulations.
- Block access to the work area before starting assembly, servicing and maintenance work to safeguard against unauthorised entering and trespassing!
- Always keep a safe distance when carrying out work on the systems!
- When working on the systems wear protective gloves, safety shoes and goggles for cutting activities!



**Danger:**

By opening and closing the systems, there is a danger of getting caught or even crushing individual limbs or the entire body.

There should be nothing in the pivoting area when opening the doors.

It is not allowed to bridge and bypass safety devices or to render them inoperable. Defective safety devices may not be rendered inoperable in order to carry on operating the system.

It is prohibited to stay in the pivoting when opening and closing as it can cause moderate and severe injuries or property damage.

### **4.3 Professional handling**

To maintain safe working order and to ensure safe operation, the user is obliged to observe the points stated in this instruction manual.

## 4.4 Hazard warnings

This chapter highlights the possible hazards of using hinged doors.

### General hazards:

- Risk of entanglement and risk of shearing between the door leaf and floor (2)
- Risk of entanglement between the door leaf and the ceiling (4)
- Risk of stumbling due to obstacles in the area of passage
- Risk of collision with door leaf
- Risk of collision with main closing edge (1)

### Hazards when opening:

- Risk of crushing between the door leaf and the adjacent wall (3)

### Hazards when closing:

- Risk of crushing at the main closing edge (1)
- Risk of crushing at the secondary closing edges (3)

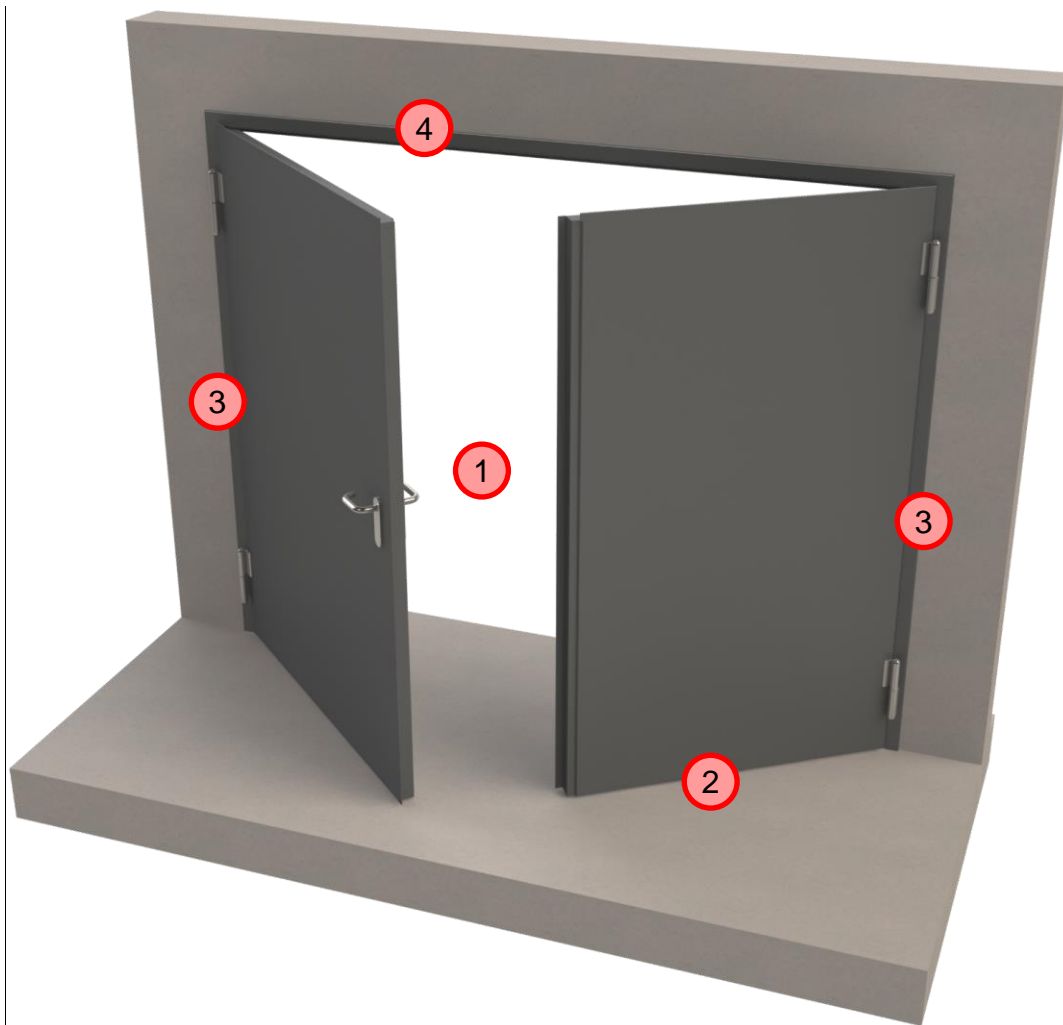

**Figure 1: Hazard points of hinged doors**

- 1 Hazard point between main closing edge and opposing closing edge
- 2 Hazard point between secondary closing edge and floor
- 3 Hazard point between secondary closing edge and opposing closing edge
- 4 Hazard point between secondary closing edge and ceiling and/or opposing closing edge

## 5 Basic instructions

### 5.1 General

This information was written with the intention of being read, understood and observed in all respects by those who are responsible for the operation, maintenance and upkeep of the door/gate system.

These instructions help you avoid danger, prevent downtime and guarantee/extend the service life of the door/gate system.

The complete technical documentation should always be kept handy.

This document draws your attention to any specifically important details regarding the use of the system.

It is only possible to avoid faults in the system and ensure trouble-free operation by reading these documents.

It is therefore essential that all responsible persons are familiar with the present instruction manual.

It is imperative to have carefully read this instruction manual **before** commissioning, since the company Hodapp GmbH & Co. KG will not accept liability for any damages or malfunctions arising from not complying with them.

The hazard warnings and safety rules in this manual must be observed without exception.

### 5.2 Competent persons

Competent persons are those persons,

- who have knowledge in the field of power-operated windows, doors and gates thanks to their professional training and experience.
- who are familiar with relevant national health and safety regulations, directives and generally accepted engineering standards

Competent persons must be asked to give their expert opinion objectively, from the standpoint of occupational safety and unaffected by operational or economic circumstances.

### 5.3 Laypersons

The lay people are persons without knowledge in technical issues regarding door/gate systems. Lay people are non-competent persons. The operator must ensure that lay people are trained in the operation of the door/gate system. However, they may not perform any assembly, commissioning, maintenance and dismantling work.

### 5.4 Intended use

The door/gate system has been designed and produced in accordance with the state of the art in technology and recognised safety regulations (**Chapter 3**).

The door/gate system components may only be used when in perfect condition. Intended use also includes following all the instructions in these operating instructions.



Improper or non-intended use of the device can cause life-threatening injuries to the user and damage the device or other property.

## 5.5 Operator's obligations



Observe operating instructions.

In case of faults, always request assistance from a competent person (expert).

Do not perform any unauthorised structural changes on the control system.

Ensure that the door systems are operated only in a perfect condition and in accordance with the valid approval at the time of commissioning, and that it is regularly checked with respect to its functioning capability by an expert (**Chapter 8**). Proof must be provided, to confirm that the necessary checks have been carried out. The operator is also responsible for ensuring that he has the operating instructions for the gate.

If spare parts are replaced, this is recorded on the checklist. It is the responsibility of the operator to take note of the test report and to have the defects rectified. The operator undertakes to comply with the applicable accident prevention regulations and to carry out any necessary maintenance work.

## 5.6 Obligations of the user

The user has an obligation to use the product as intended.

## 5.7 Warranty and liability

A functionally correct operation and handling as well as an error-free connection of all command, signaling and drive elements are all expected if resorting to warranty. The manufacturer guarantees that all parts are free of faults in materials and workmanship at the time of delivery.



Our "general terms and conditions" apply generally, which can be accessed by downloading them from the Hodapp website. In addition, they are available to the operator at least by the time the contract is concluded. In the event of personal injury and property damage, warranty and liability claims are waived if they are attributable to one or more of the following causes:

- Failure to follow the instructions in the operating instructions in relation to project planning, storage, assembly, commissioning and servicing.
- Improper use.
- Wind damages.
- Operating the system with defective safety devices or, safety devices and protective devices which have not been attached properly or are not in good working order.
- Unauthorised structural modifications to the door/gate system components.
- Repairs that are not carried out professionally.
- Disasters caused by external influence and force majeure.



The manufacturer accepts no liability for damage caused by incorrect operation or connection, non-compliance with the operating instructions or lack of maintenance or care.

## 5.8 Safety measures for assembly, commissioning and maintenance



Ensure that the system's power supply is disconnected and secured against accidental reconnection before carrying out any electrical work on the door/gate.

Only qualified electricians are allowed to carry out work on the electrical parts.

Never override or bypass safety devices.

Block access to the work area before starting assembly, servicing and maintenance work to safeguard against unauthorised entering and trespassing. (The employers' liability insurance association Regulation BGV A 8 Section 12 "Obstacles and danger zones" stipulates that temporary obstacles and danger zones must be indicated.)

## 5.9 Residual risk analysis



If not all crushing and shearing points can be avoided or secured for technical or structural reasons, or due to customer-specific requirements, the operator has to carry out a residual risk analysis. This must be seen and observed.

## 5.10 Packaging

The components are packaged in accordance with the transport conditions to be expected. This helps with protection from transport to assembly. Removing the packaging just before assembly is recommended.



Packaging material is to be disposed of in accordance with statutory regulations and local provisions.

## 5.11 Disposal

The door systems must be disassembled and disposed of in accordance with the relevant directives and regulations, or returned to the manufacturer. The disposal of the products is subject to the respective national legislation.



The systems contain coated metal components, electronic components, cables, insulation materials, plastics, etc. and must be disposed of in accordance with the applicable environmental regulations

## 6 Assembly and installation

### 6.1 Safety notes for assembly



Only original replacement parts may be used. The manufacturer's liability terminates if other parts are used. Specific safety requirements and accident prevention regulations must be observed during the installation, commissioning, maintenance and inspection of the product. These include in particular all the standards listed in the **Chapter 3**. Only qualified technical personnel may carry out the required assembly of the systems.

#### The following should be particularly noted:

- Replacement work should be only carried out on a de-energized system.
- Please proceed with caution if carrying out work which requires the door system to be switched on.
- If a fault occurs which could affect personal safety, the system must be rendered inoperative.
- It may only be put back into operation after the fault has been rectified professionally and the danger is eliminated.
- It is generally not allowed to bridge and bypass safety devices or to render them inoperable.
- Defective safety devices may not be rendered inoperable in order to carry on operating the system.
- Subsequent changes and modifications to the system may only be carried out by authorized service personnel, while taking into account the limits of application.
- Should there be any damages or faults that cannot be rectified immediately, the operator of the system must be informed immediately and the system rendered inoperative.
- Repairs must take place as rapidly as possible.
- All door component screws loosened during replacement must be retightened to the recommended torque values by means of a torque wrench.
- If the replacement of system components is not performed as described, the manufacturer disclaims any liability with regard to functionality and safety.
- Disassembly should always be in the reverse order of assembly.
- We accept no liability for corrosion damage if a professional final coating has not been carried out within three months of installation. Components such as seals and locks as well as other fittings must not be painted over.

## 6.2 Electrical connection



The assembly, commissioning and maintenance as well as work on open electrical parts with live voltage may only be performed by a qualified electrician.

Before starting any work on the systems, it is important to secure any electrical power sources and ancillary equipment from accidental switch-on.

To avoid engine damage, an existing thermal protection must always be connected in the safety circuit.

Check that the line terminals are fitted snugly before switching on.

Power the systems from undamaged electrical installations only. Defective electrical installations can lead to an electrical shock or a short circuit.

## 6.3 Fasteners

- Screws with a hexagon head or hexagon socket head can be tightened to the required tension with a torque wrench.
- Slotted or Phillips screws should be tightened to the extent that a secure hold is ensured (subjective) without damaging the tool holder.
- When selecting the torque according to the attached table, you have to take into account the corresponding class of materials.
- The material classes are identified by the marking on the screw head. Generally, the fasteners used have a strength class of 8.8 in case of steel or class 70 if stainless steel.
- From now on, all fasteners on elements and locks intended for use in the tunnel must be permanently secured against loosening either by mechanical means (e.g. spring rings, spring washers) or chemically (e.g. thread locking fluid, glue). Threads must be clean when using thread locking fluid. It is not permitted to combine lubricant with thread locking fluid.
- The assembly instructions and the boundary conditions provided by the respective manufacturer must be observed when fitting dowels.

**Tightening of screws/bolts and nuts:**

All screws/bolts and nuts must be tightened with a torque wrench as follows:

Tightening torques (Nm)				
Connection	Steel		Stainless steel A2 / A4	
Strength class	8.8	10.9	70	
Surface	Lightly oiled or galvanised ( $\mu = 0,14$ )		greased ( $\mu = 0,2$ )	dry ( $\mu = 0,3$ )
<b>M 4</b>	3,0	4,4	2,6	3,0
<b>M 5</b>	5,9	8,7	5,1	6,1
<b>M 6</b>	10	15	8,8	10,4
<b>M 8</b>	25	36	21,4	25,5
<b>M 10</b>	49	72	44	51
<b>M 12</b>	85	125	74	88
<b>M 14</b>	135	200	119	141
<b>M 16</b>	210	310	183	218
<b>M 18</b>	300	430	260	308
<b>M 20</b>	425	610	370	439
<b>M 22</b>	580	820	488	582
<b>M 24</b>	730	1050	608	724
<b>M 27</b>	1100	1550		
<b>M 30</b>	1450	2100		

The values in the table apply in accordance with VDI 2230 for:

- Screw connections made of steel / stainless steel in specified strength classes
- Headrests such as ISO 4017 (DIN 933), ISO 4762 (DIN 912), etc.
- Utilisation of the minimum yield strength = 90 %

All data are non-binding guide values.



## 6.4 Assembly requirements

### 6.4.1 Checking delivery for completeness

Prior to installing the door, check the delivery for completeness. The delivery scope results from the parts list.

### 6.4.2 Checking the wall opening

Prior to starting the installation process, check whether the wall opening complies with the information in the technical drawings according to DIN 18202.

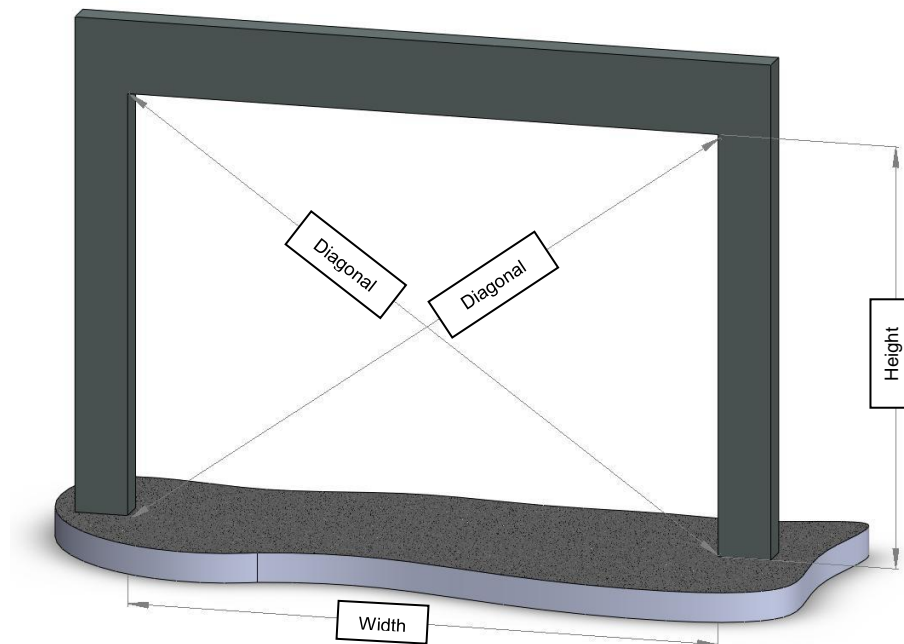

### 6.4.3 Overview of anchor positions and screw connections

The number of fastening points and screw connections depends on the door size and model. See the relevant drawing to determine anchor positions and types.

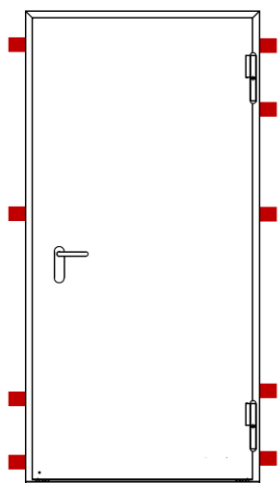

**Figure 3: Anchor positions in single-leaf door**

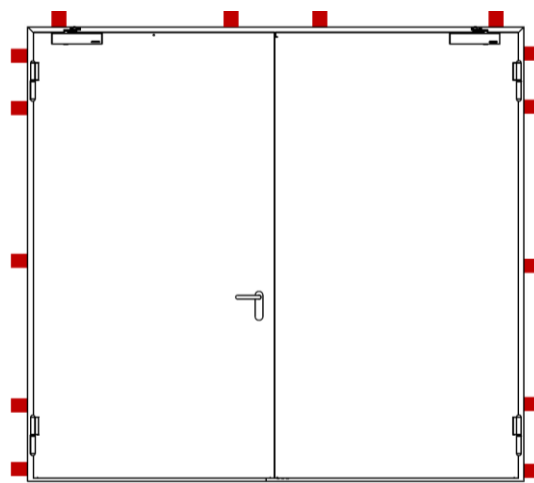

**Figure 4: Anchors position in double-leaf door**

The number of fastening points and screw connections depends on the door size and model. See the relevant drawing to determine anchor positions and types.

## 6.5 Door installation

The illustrations in these instructions are principle drawings. Precise designs can be found in the project drawings.

Ensure that the structural capability of the frame where the door will be installed has been designed for the gate weight.

The owner needs to inspect / verify this structural capability.

Use only standardised fasteners and/or fasteners with a technical approval and/or a European Technical Assessment.

Follow the installation instructions and the boundary conditions provided by the fastener manufacturer.

**Check the frame elements and the floor rail for correct horizontal and vertical positioning and installation, use shimming material if necessary.**

### 6.5.1 Assembling the frame parts

Depending on the door size and model, the frame is delivered assembled or in individual parts. If the frame has to be screwed together on site, the following steps must be observed.

- 1 Plug together frame components
- 2 Use Allen cylinder screws (M5) to screw the frame parts together
- 3 Additionally, use grub screws (M5) to firmly fix the frame parts

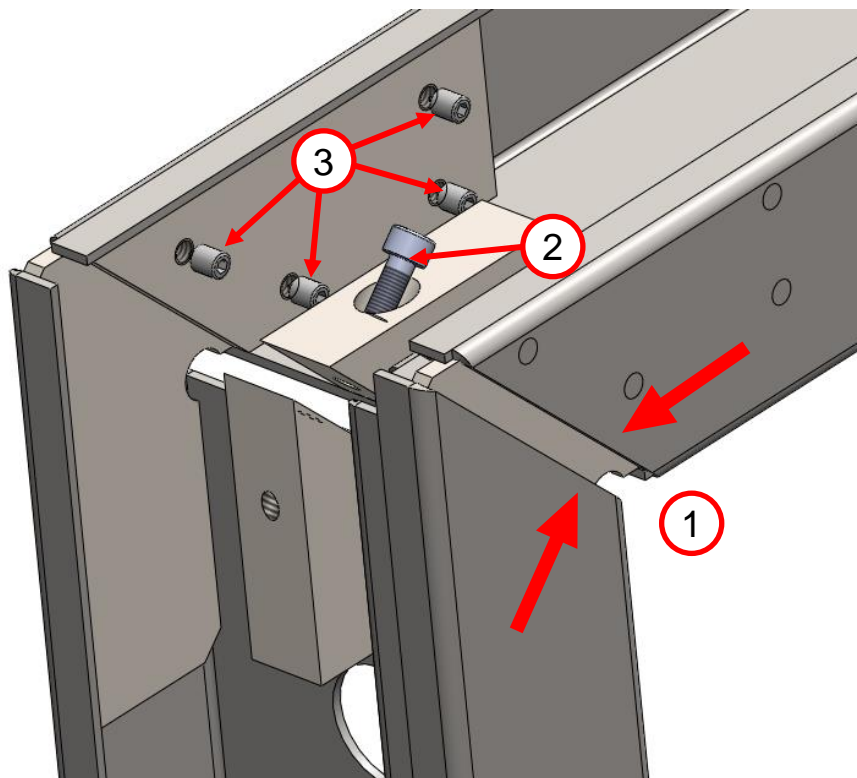

Figure 5: Assembling the frame parts

## 6.6 Stages of assembly

- Check that the welded anchor tabs are complete
- Insert the frame in the opening. Align horizontally and vertically according to the reference level, and fix in place

### Important note !!!

- For the execution with the Hodapp 3D-Hinges, all anchors must be placed on the hinge side before the wing is hooked in. For all other hinges, only the upper anchor or dowel on the hinge side must be placed).

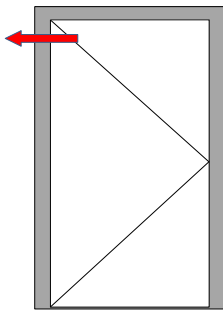

Hinge type KOF / KOH / XXL

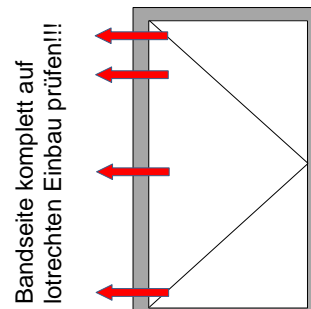

Hinge type 3D-Objektband

- Hook the door leaf into the frame by means of a vacuum suction system or the mounting suspension (M16) located at the upper edge of the leaf and aligns it with uniform air gaps.
- Fasten remaining anchors completely
- Align, underlay and fasten floor rail
- Backfill frame with masonry mortar (Group  $\geq$  II according to DIN 1053 or DIN 1996-1-1 / Class  $\geq$  M10 according to EN 998-2).\*
- Depending on the design, backfilling can also be carried out with assembly foam or mineral fibre insulating materials.
- Securing the hinges by screwing in the setscrews
- Insert sealing profile
- Fasten the lever handle set and check that the lever handle moves smoothly
- If necessary, fit and adjust door closer
- Check that the complete bolt exclusion is guaranteed.

Additives: Silicone, etc.

\*The adhesive bond between frame and mortar does not have to be proven, so that it is irrelevant if the mortar detaches from the frame or masonry after setting (hairline cracks).

### 6.6.1 Raising and fixing the frame

When erecting the frame, make sure that the axis of the shell opening corresponds to the axis of the frame.



Ensure collinear alignment of the vertical frame surfaces to avoid malfunctions. Otherwise, it cannot be guaranteed that the door leaf will close smoothly. Further, it must be ensured that the door leaf has uniform clearance from both parts of the frame.

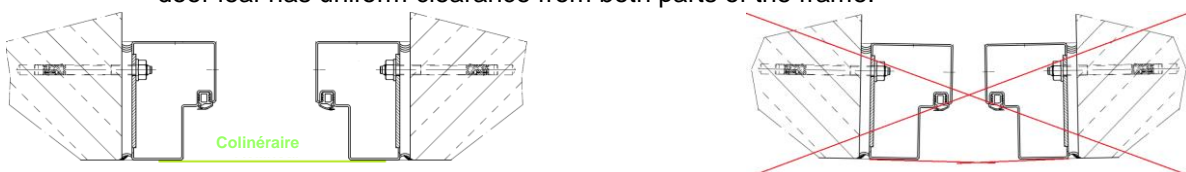
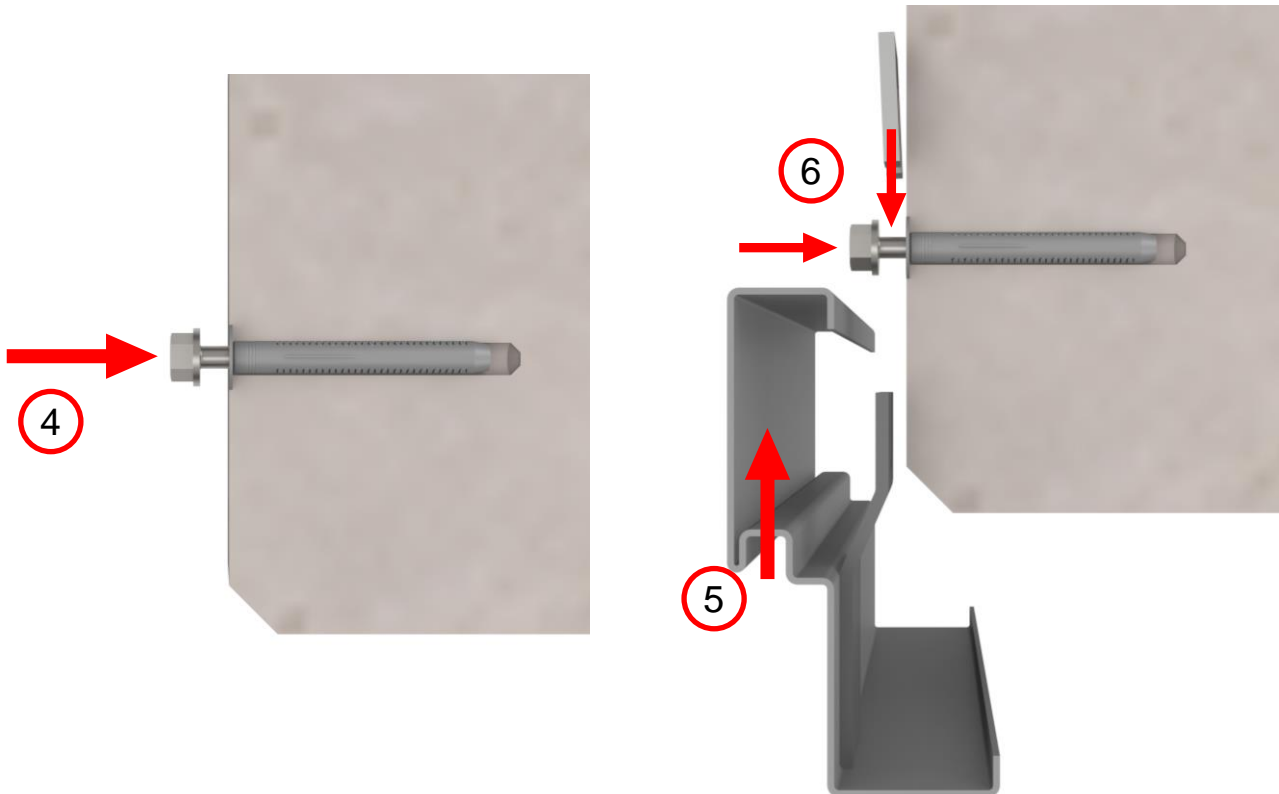
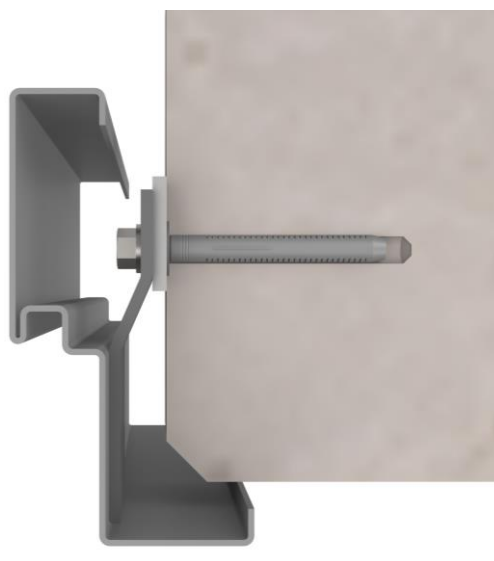

Figure 6: Aligning the frame surfaces

**6.6.2 Corner frame with invisible fixing (screw mounting)**

- 1 Insert the frame in the opening, align horizontally and vertically according to the cutting check and fix in place
- 2 Mark the position of the anchor locations and remove the frame from the reveal
- 3 Drill holes for the wall plugs
- 4 Insert the dowels into the holes and screw them in lightly
- 5 Reinsert the frame in the reveal
- 6 Insert wall plugs and screws and back-fill with underneath material made from steel or plastic
- 7 Tighten screws (see 6.3)

**Abbildung 7: Assembly of the corner frame****Abbildung 8: Fully assembled corner frame**

**6.6.3 Corner frame with invisible fixing (welding assembly)**

- 1 Insert the frame in the opening, align horizontally and vertically according to the cutting check and fix in place
- 2 Mark the position of the anchor locations and remove the frame from the reveal
- 3 Drill holes for the wall plugs
- 4 Affix the weld-on plate with screw and wall plug
- 5 Reinsert the frame in the reveal
- 6 Weld the frame to the weld-on plate

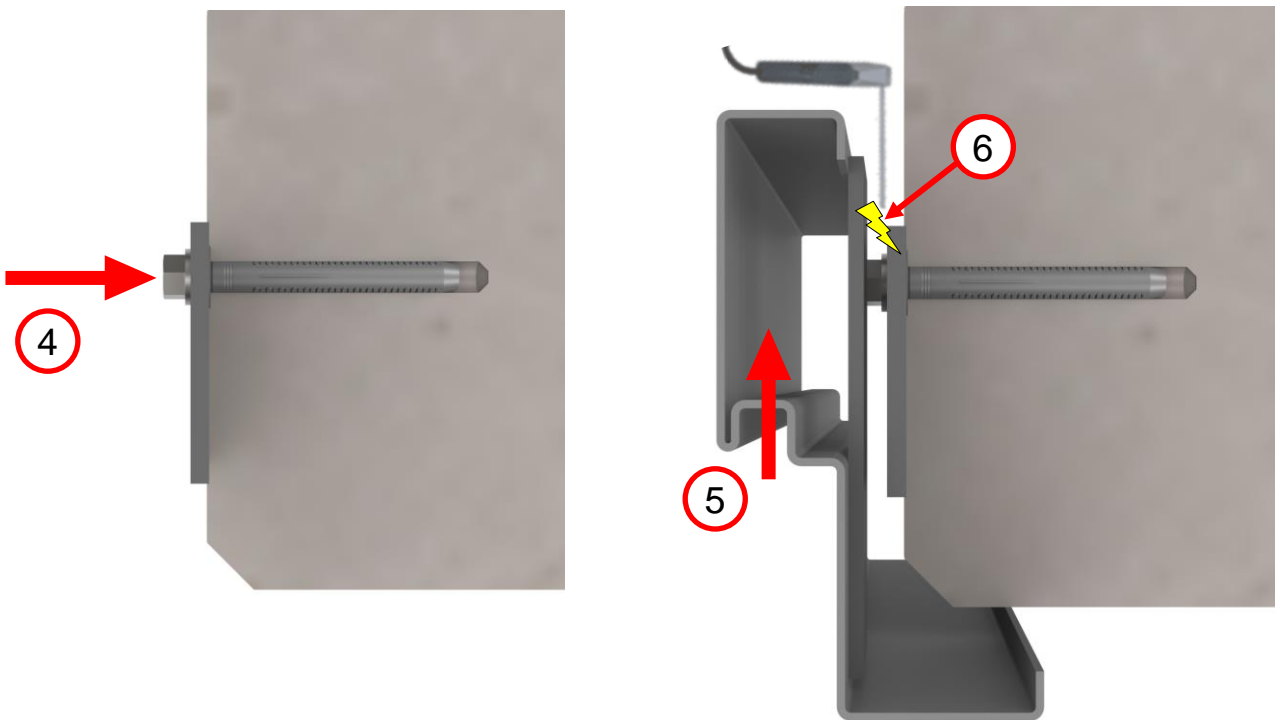
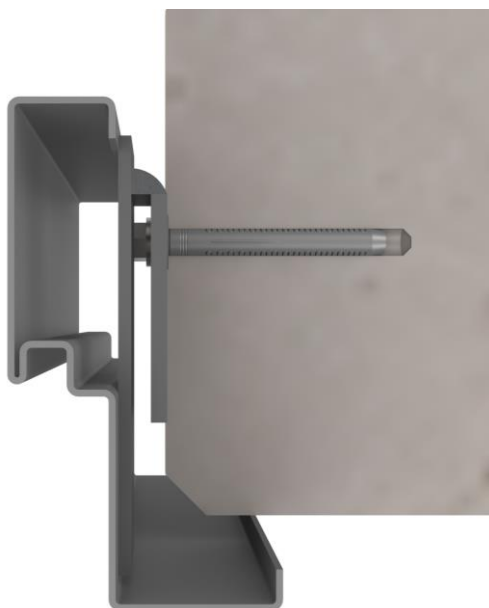
**Figure 9: Assembly of the corner frame****Figure 10: Fully assembled corner frame**

**6.6.4 Block frame**

- 1 Place the frame in the opening or in front of the wall, align horizontally and vertically according to the cutting check and fix in place
- 2 Drill anchor positions
- 3 Insert wall plugs and screws and back-fill with underneath material made from steel or plastic
- 4 Tighten screws (see 6.3)
- 5 Insert cover caps

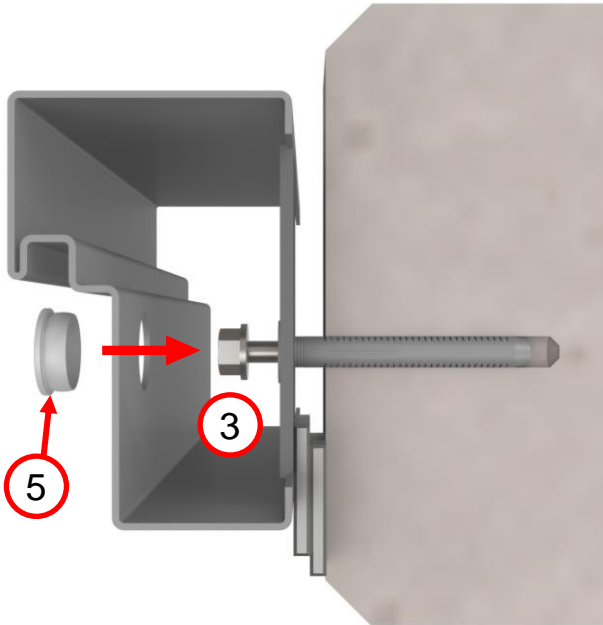

Figure 11: Assembly of the block frame

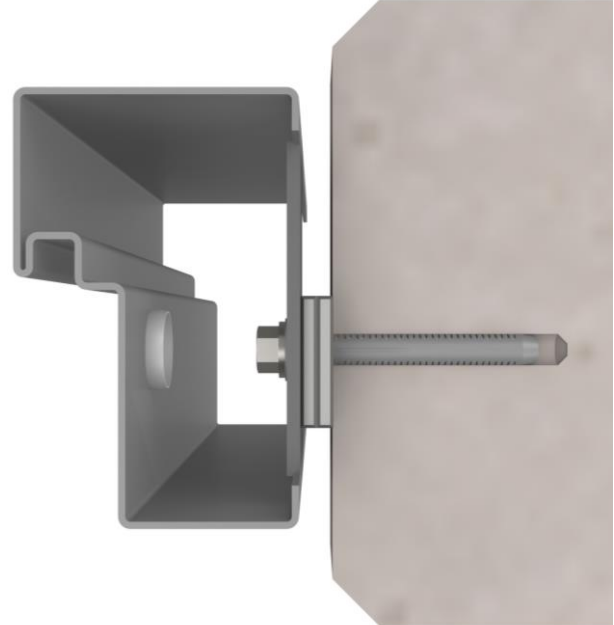

Figure 12: Fully assembled block frame

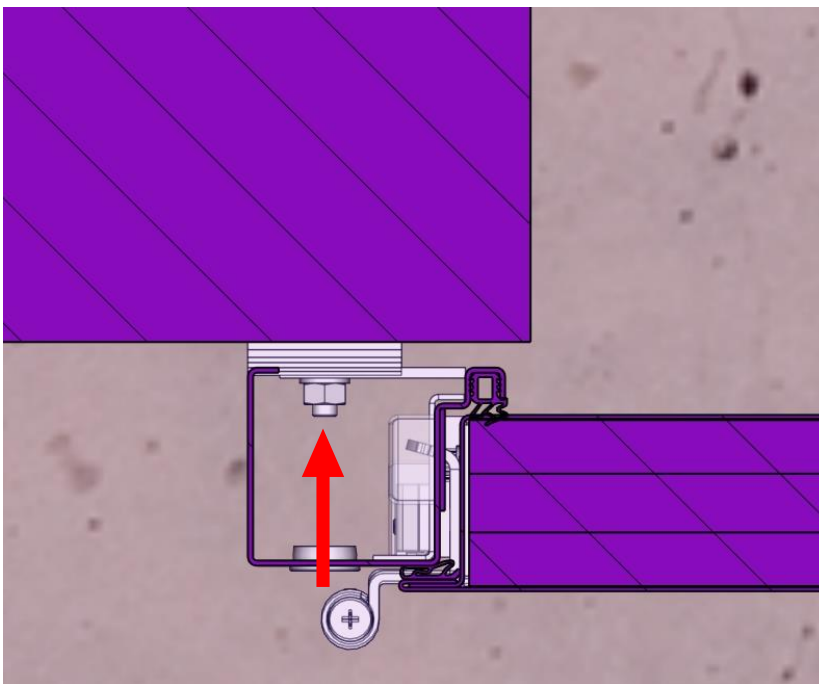

Figure 13: Assembly of the block frame

### 6.6.5 Block frame in 2-parts with invisible fixing

- 1 Insert the frame in the opening, align horizontally and vertically according to the cutting check and fix in place
- 2 Mark the position of the anchor locations and remove the frame from the reveal
- 3 Drill holes for the wall plugs
- 4 Reinsert the frame in the reveal
- 5 Insert wall plugs and screws and back-fill with underneath material made from steel or plastic
- 6 Tighten screws (see 6.3)
- 7 Insert the counter frame
- 8 Screw in counter frame

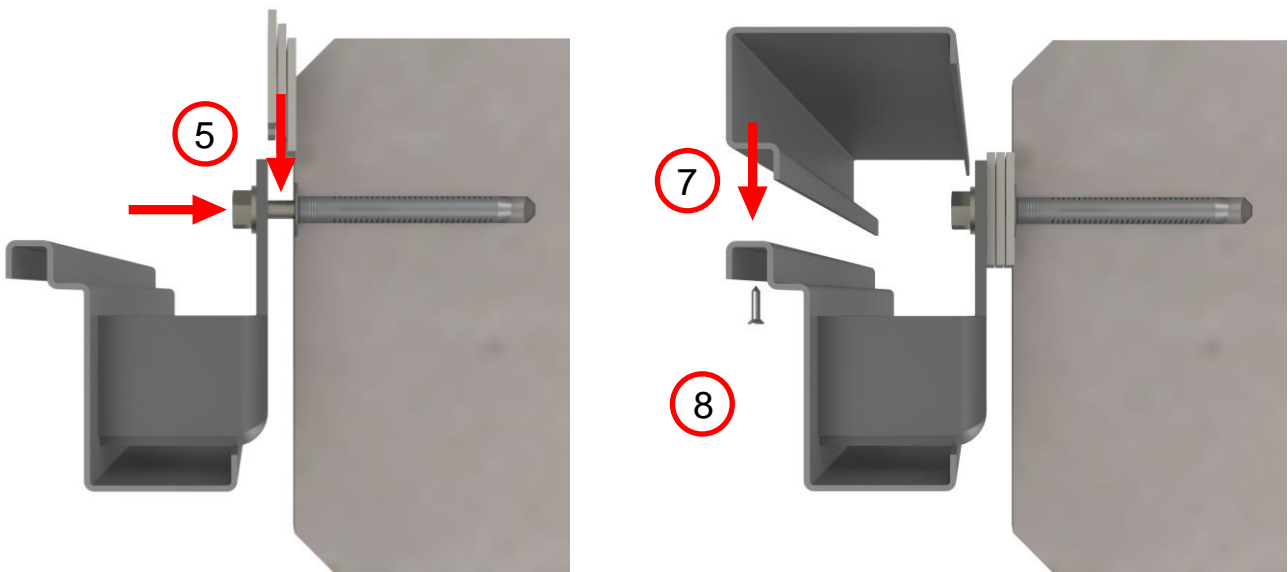

Figure 14: Assembly of the block frame in 2-parts

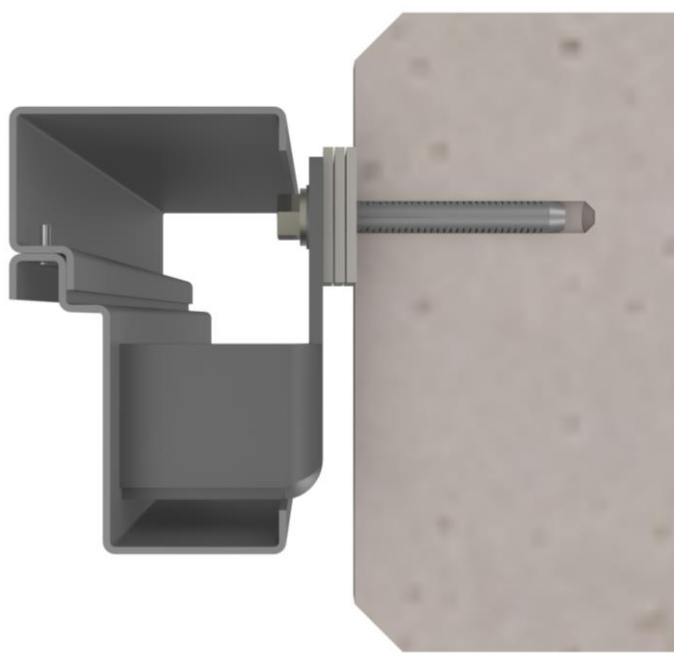
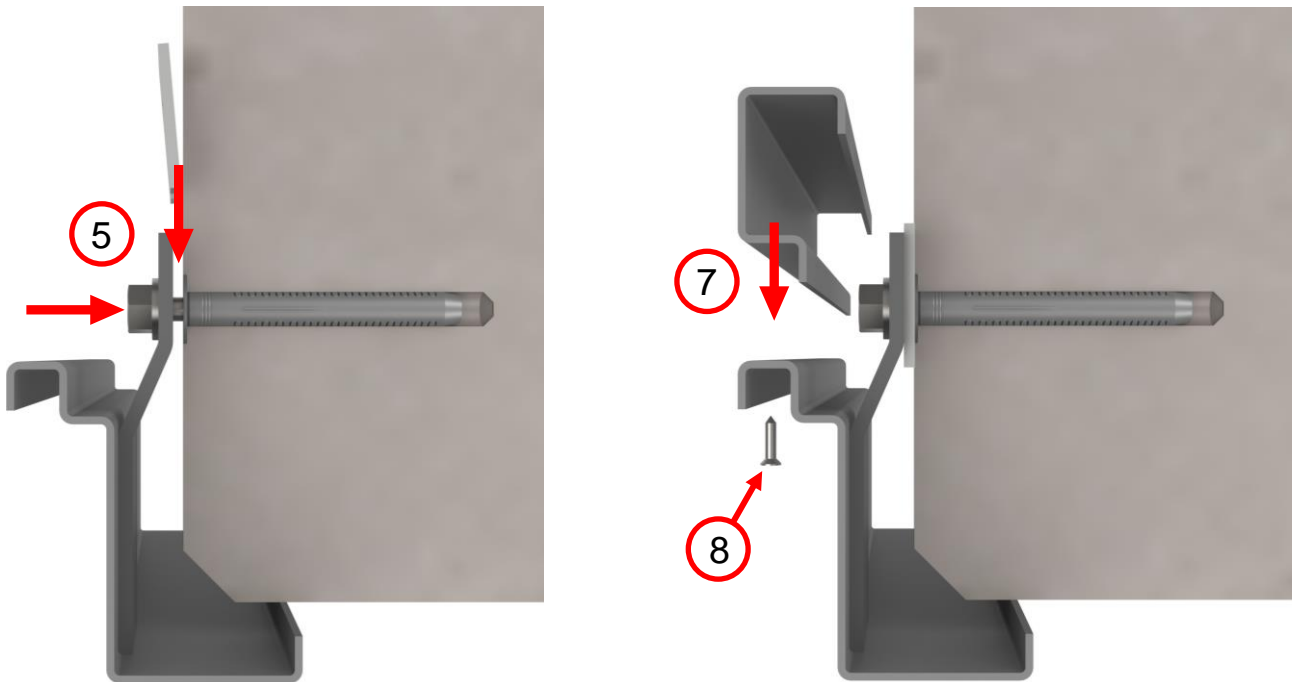
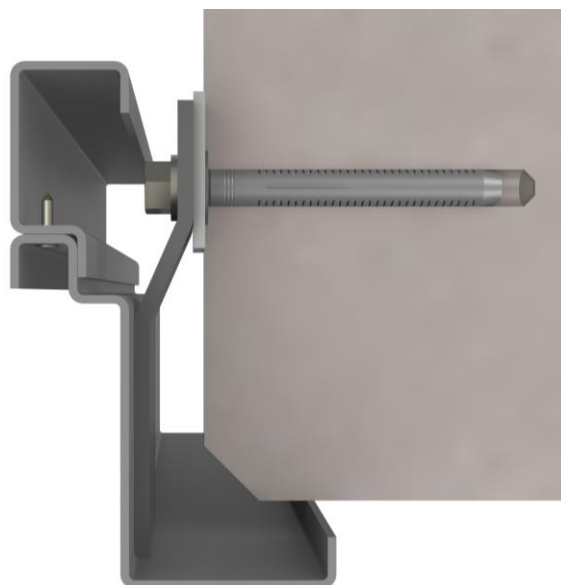

Figure 15: Fully assembled block frame in 2-parts

**6.6.6 Plug-in frame with invisible fixing**

- 1 Insert the frame in the opening, align horizontally and vertically according to the cutting check and fix in place
- 2 Mark the position of the anchor locations and remove the frame from the reveal
- 3 Drill holes for the wall plugs
- 4 Reinsert the frame in the reveal
- 5 Insert wall plugs and screws and back-fill with underneath material
- 6 Tighten screws
- 7 Insert plug-in frame
- 8 Screw in plug-in frame

**Figure 16: Assembly of the plug-in frame****Figure 17: Fully assembled plug-in frame**



### **6.6.7 Floor connection**

#### **Retractable floor seal**

Affix the floor seal using the attachment bracket supplied. For this purpose, place the pre-assembled floor seal into the groove on the bottom edge of the door. Fit the attachment bracket into the floor seal and screw on the door leaf using the screws supplied. By turning the control knob, set the stroke so that the sealing strip closes cleanly when the door is closed.

If necessary, refer to the manufacturer's assembly and adjustment instructions.

## 6.7 Hinge installation

### 6.7.1 Hinge KOF 2-parts

#### 6.7.1.1 Components

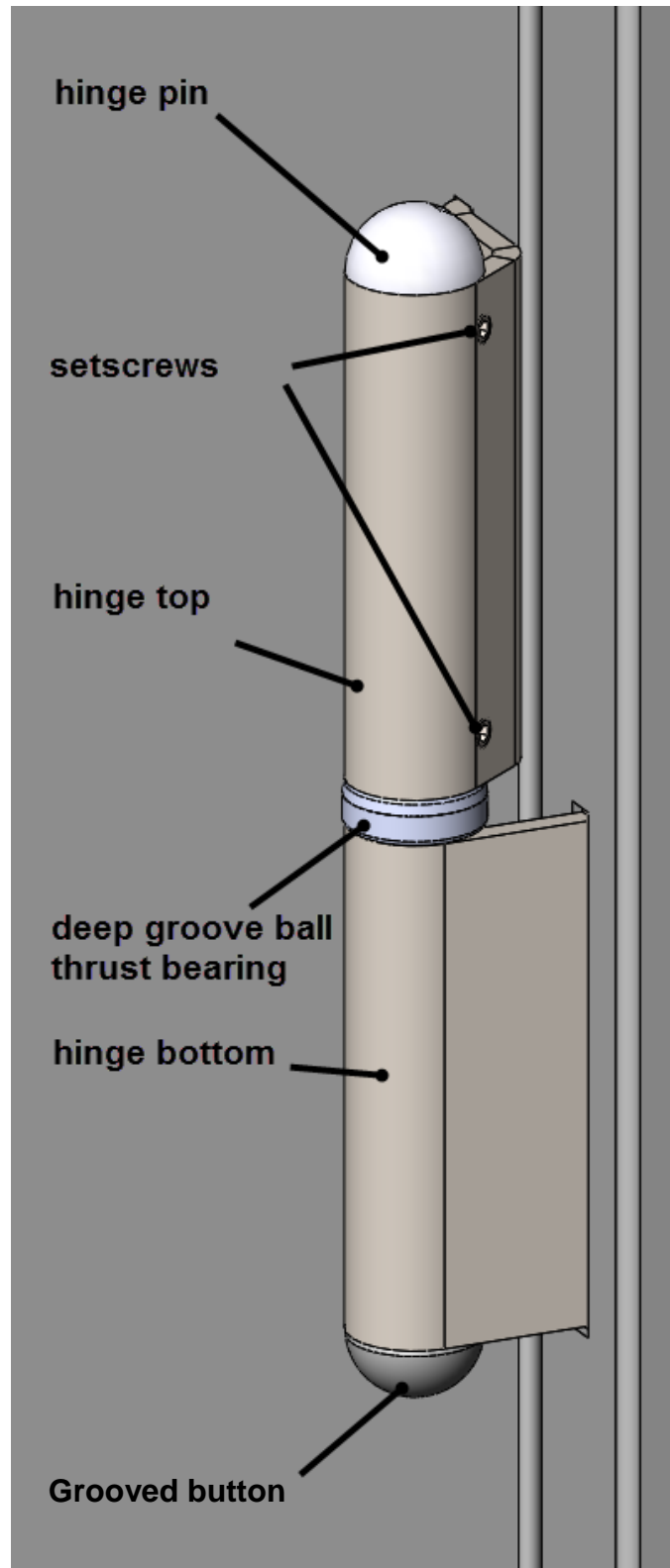

### 6.7.1.2 Hinge installation

### 6.7.1.3 Mounting accessories

#### Assembly components:

The hinge pin, the deep groove ball thrust bearing, the setscrews M6 (2 pieces) and the rutted button are packed and supplied as assembly for each door.

#### Assembly tools:

- Allen key M6 (A/F 3)
- Soft face hammer/ Drift pin punch in steel, stainless steel, aluminium, copper, hardwood

#### 6.7.1.3.1 Stages of assembly

1. Order of hinge installation: lower hinge (1), upper hinge (2), if available middle hinge (3).

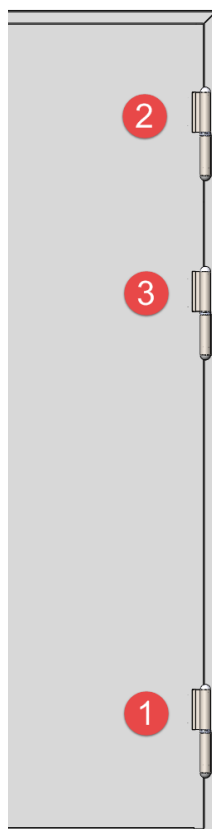

2. Insert the door leaf in frame and align the lower part of the frame hinge and the upper part of the door hinge horizontally and vertically.
3. Insert the deep groove ball thrust bearing between the upper and the lower part of the hinge.
4. Drive in the hinge pin from above.  
For stainless steel don't use the usual steel drift pin punch to drive in the hinge pin, but a drift pin punch made of stainless steel, aluminium, copper, hardwood.  
Work carefully to protect the deep groove ball thrust bearing from any damage.
5. If necessary grease the hinge by the recess at the head of the hinge pin.
6. Screw the setscrews (M6) for safe position of the hinge in the provided thread holes.
7. Tap the rutted button from below for force fit.

**6.7.2 Hinge KOF 3-parts**

**6.7.2.1 Components**

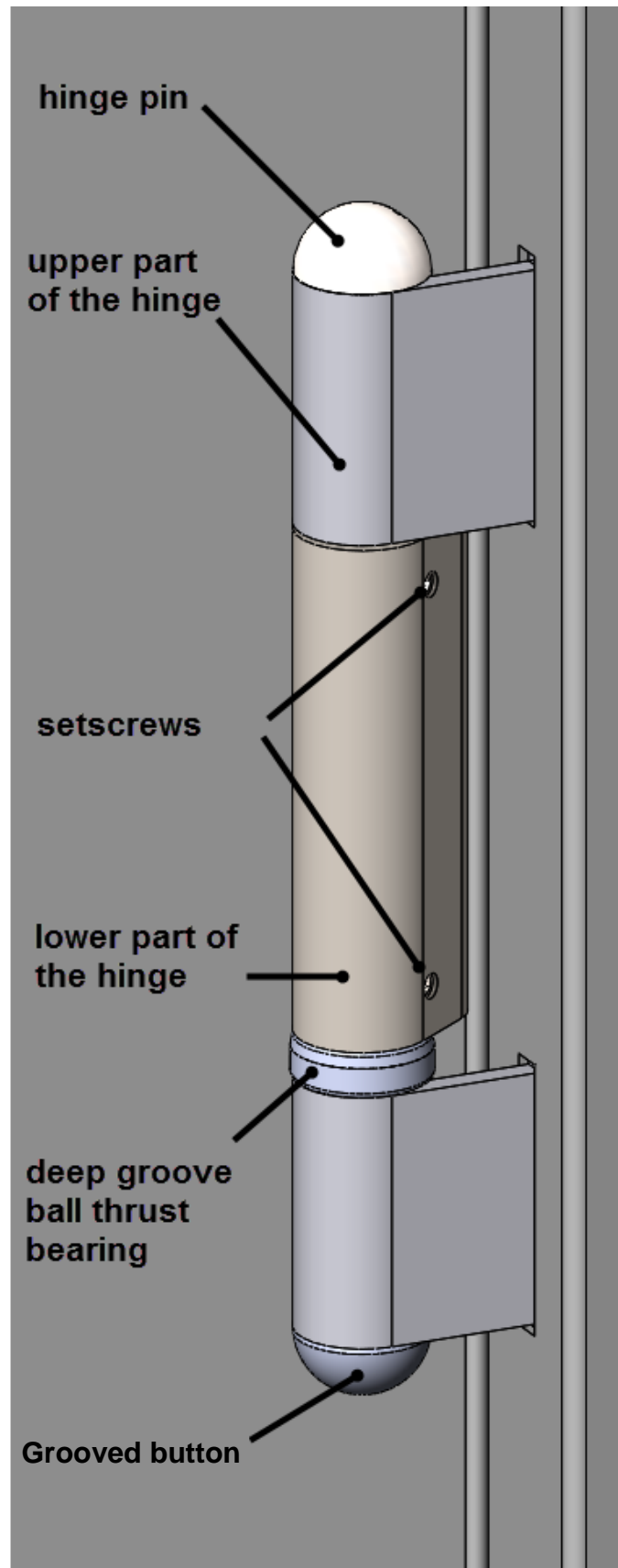

### 6.7.2.2 Hinge installation

### 6.7.2.3 Mounting accessories

#### Assembly components:

The hinge pin, the deep groove ball thrust bearing, the setscrews M6 (2 pieces) and the grooved button are packed and supplied as assembly for each door.

#### Assembly tools:

- Allen key M6 (A/F 3)
- Soft face hammer/ Drift pin punch in steel, stainless steel, aluminium, copper, hardwood

#### 6.7.2.3.1 Stages of assembly

1. Order of hinge installation: lower hinge (1), upper hinge (2), if available middle hinge (3)

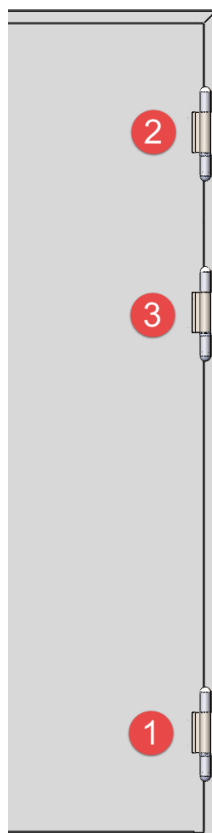

2. Insert the door leaf in frame and align the lower part of the frame hinge and the upper part of the door hinge horizontally and vertically.
3. Insert the deep groove ball thrust bearing between the upper and the lower part of the hinge.
4. Drive in the hinge pin from above.  
For stainless steel don't use the usual steel drift pin punch to drive in the hinge pin, but a drift pin punch made of stainless steel, aluminium, copper, hardwood.  
Work carefully to protect the deep groove ball thrust bearing from any damage.
5. If necessary grease the hinge by the recess at the head of the hinge pin.
6. Screw the setscrews (M6) for safe position of the hinge in the provided thread holes.
7. Tap the grooved button from below for force fit.

### 6.7.3 KOH-3D - Stainless steel door hinge

#### 6.7.3.1 Components

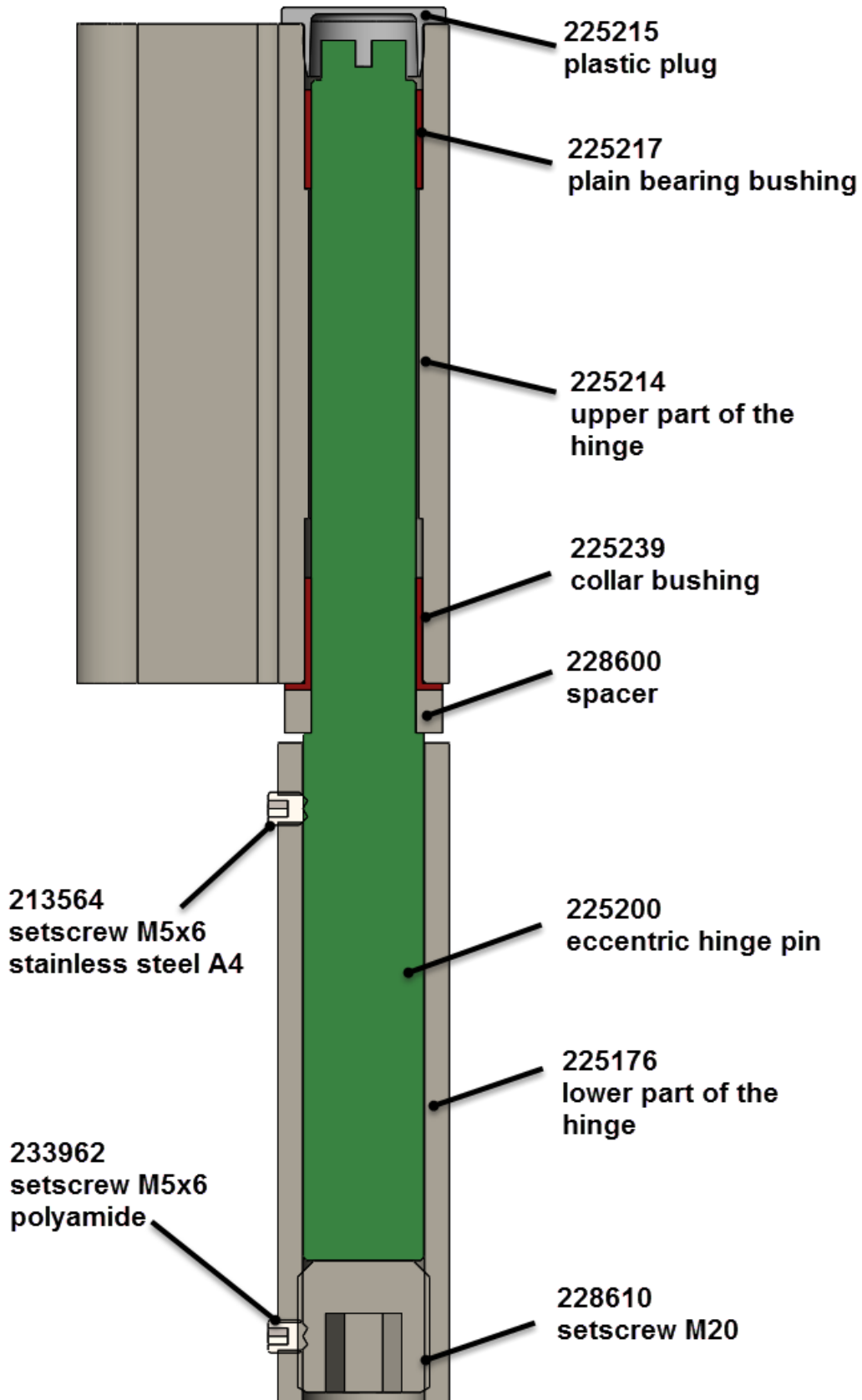

### 6.7.3.2 Hinge installation

#### 6.7.3.3 Mounting accessories

##### Assembly components:

The hinge pin, the spacer, the setscrews M20 and M5 (2 pieces) and the end cap are packed and supplied as assembly for each hinge.

##### Assembly tools:

- Allen keys M5 (A/F 2.5) and M20 (A/F 10)
- Soft face hammer/ Drift pin punch in stainless steel, aluminium, copper, hardwood

#### 6.7.3.3.1 Stages of assembly

1. First of all insert the hinge pin and the spacer at the lower hinge for reasons of accessibility.
2. order of hinge installation: lower hinge (1), upper hinge (2), if available middle hinge (3)

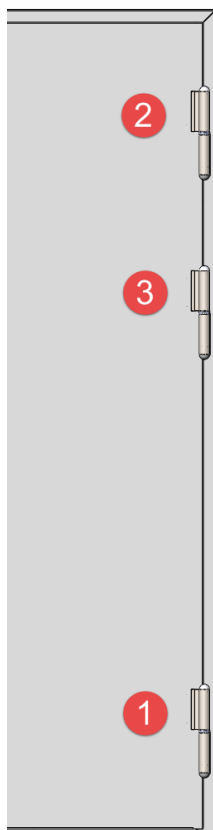

3. Insert the door leaf in frame and align the lower part of the frame hinge and the upper part of the door hinge horizontally and vertically.
4. Insert the spacer between the upper and the lower part of the hinge.
5. Drive in the hinge pin from below.  
For stainless steel don't use the usual steel drift pin punch to drive in the hinge pin, but a drift pin punch made of stainless steel, aluminium, copper, hardwood.  
Work carefully to protect the anti-friction bushes from any damage.
6. Align the hinge pin orthogonally to the frame. (as specified below)

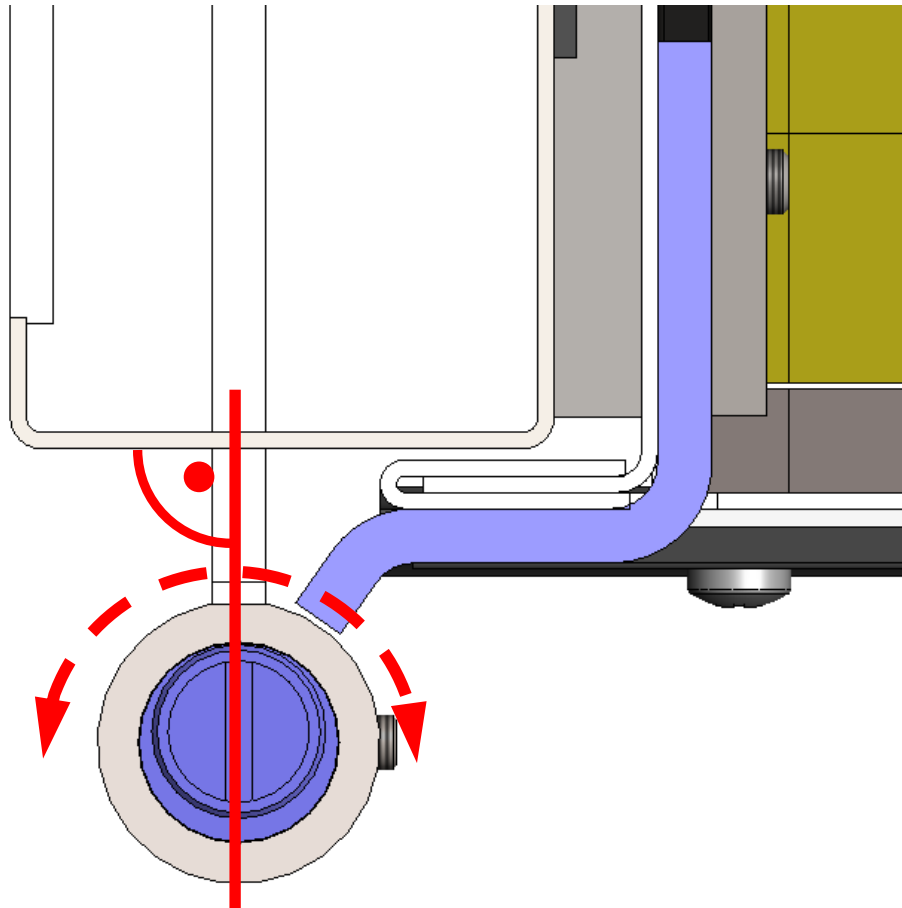

7. Screw the setscrew M5 (stainless steel A4) for safe position of the hinge in the provided thread holes.
8. Screw the setscrew M20 in the lower part of the hinge and cinch it with a setscrew M5 (PA).
9. Consider the neutral position of the height adjustment as specified below.

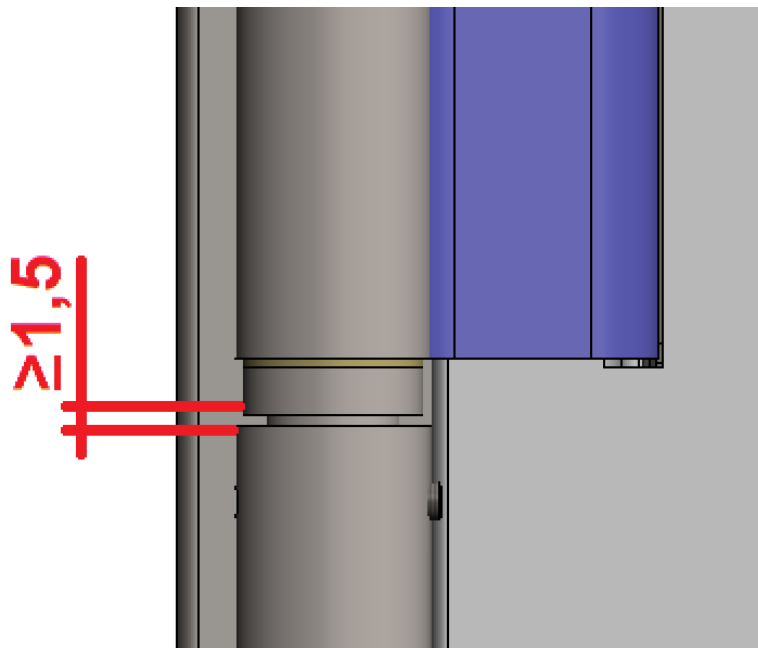

10. Put on the end cap made of plastics.



## 6.7.4 3D-Hinge

### 6.7.4.1 Assembly tool

- (Mini-) ratchet with Allen key **S5**
- Allen wrench, Allen T-wrench or (mini-) ratchet with Allen bit attachment **S2,5**
- Resin-free oil / grease, fine mechanical oil or comparable



Do not use an Allen wrench, Allen T-wrench or similar for size S5 Allen screws!



### 6.7.4.2 Assembly of the hinges

1. Place the door leaf in front of the frame and underlay it according to the soil air
2. Slightly loosen the clamping screws of the hinge holder in the frame  
>>>Tip: If the "threading" of the 3D bands is not possible, it is recommended to completely loosen the screws 1+3
3. Insert the door leaf with the hinge parts into the hinge receptacle
4. Insert the clamping screws again if necessary and tighten them firmly

### 6.7.4.3 Replacing the hinges

1. Open the leaf and secure with wedges
2. Slightly loosen the clamping screws on the frame
3. Pull the door leaf out of the frame and secure it against falling over
4. Remove the cover plate from the door leaf
5. Unscrew the hinge

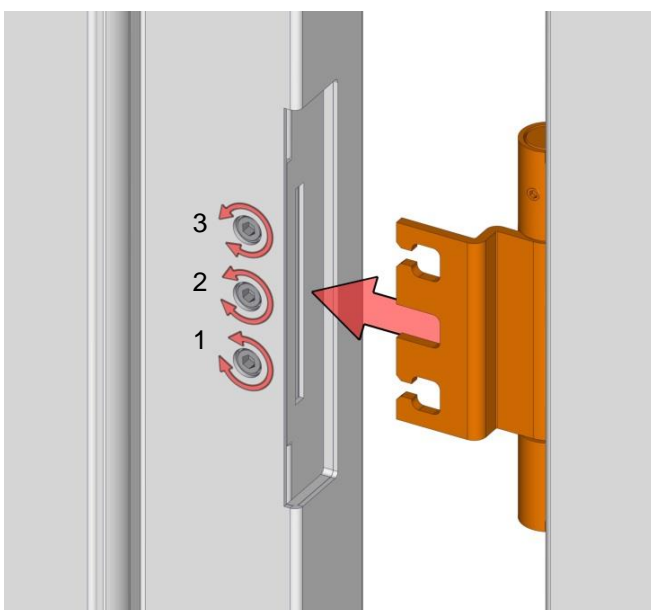

Assembly the hinges

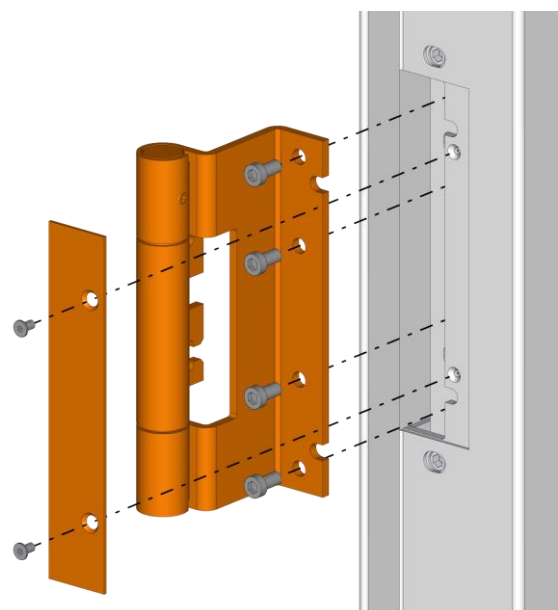

Replacing the hinges

**6.7.5 Hinge XXL**

**6.7.5.1 Components**

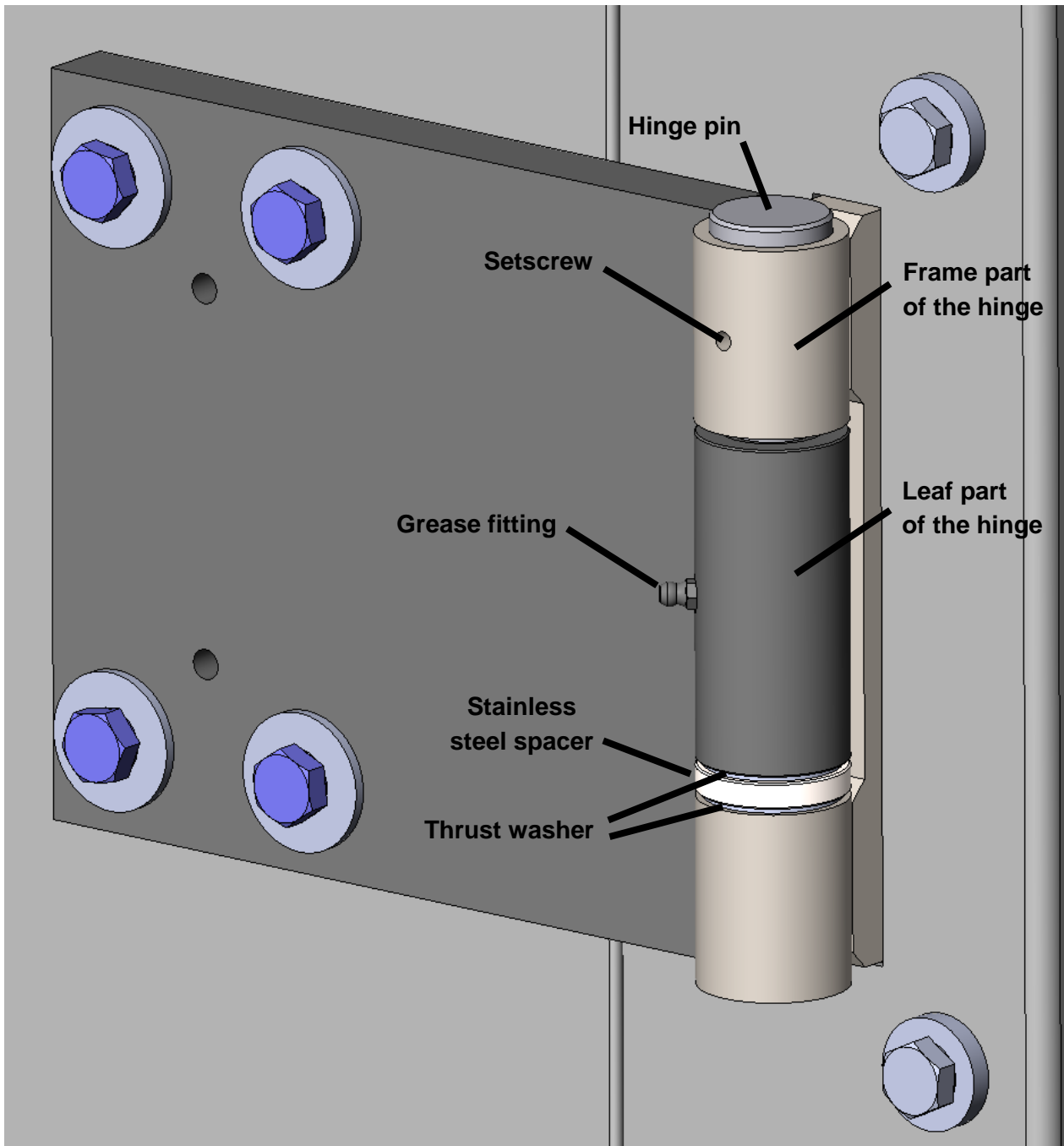

## 6.7.5.2 Hinge installation

### 6.7.5.2.1 Mounting accessories

#### Assembly components:

The hinge pin, the deep groove ball thrust bearing with protection, the setscrew M6 and the grease fitting M6 are packed and supplied as assembly for each door!

#### Assembly tools:

- Allen key M6 (A/F 3)
- Screw-wrench M18 (A/F 18)
- Soft face hammer / Drift pin punch in stainless steel, aluminium, copper, hardwood

### 6.7.5.2.2 Stages of assembly

1. order of hinge installation: lower hinge (1), upper hinge (2), if available middle hinge (3)

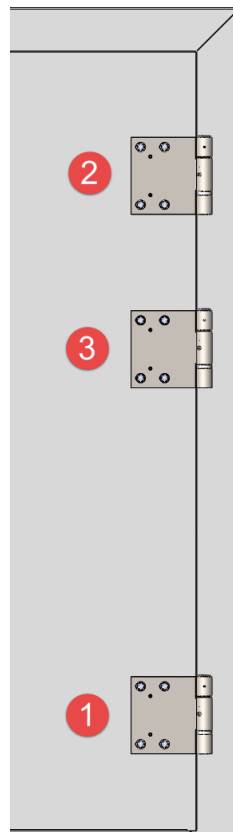

2. Insert the door leaf in frame and align the lower part of the frame hinge and the upper part of the door hinge horizontally and vertically.
3. Insert the deep groove ball thrust bearing with protection between the upper and the lower part of the hinge.
4. Drive in the hinge pin from above.  
For stainless steel don't use the usual steel drift pin punch to drive in the hinge pin, but a drift pin punch made of stainless steel, aluminium, copper, hardwood.  
Work carefully to protect the deep groove ball thrust bearing and the anti-friction bushes from any damage.
5. Screw the setscrew (M6) for safe position of the hinge in the provided thread hole.
6. Screw the grease fitting M6 in the provided thread hole on the door part of the hinge.
7. Drill holes and insert pins

## 6.8 Adjusting the door hinges

Check the function of the door leaf as well as its alignment in the frame using a tape measure; see the figure below. Ideally, all dimensions should be equal. The hinges must be readjusted if the dimensions are not equal and the door leaf collides with the frame when opening and closing.

The following descriptions apply to doors with a DIN left design. DIN right doors are handled in the exact opposite manner (mirror-inverted).

- Situation 1:** Bend upper part of the hinge outward. If this is insufficient, the lower part of the hinge can also be bent toward the centre of the door.
- Situation 2:** Bend upper hinge toward the centre of the door. If this is insufficient, the lower hinge can also be bent outward.
- Situation 3:** Bend lower hinge outward. If this is insufficient, the upper hinge can also be bent toward the centre of the door.
- Situation 4:** Bend lower hinge toward the centre of the door. If this is insufficient, the upper hinge can also be bent outward.

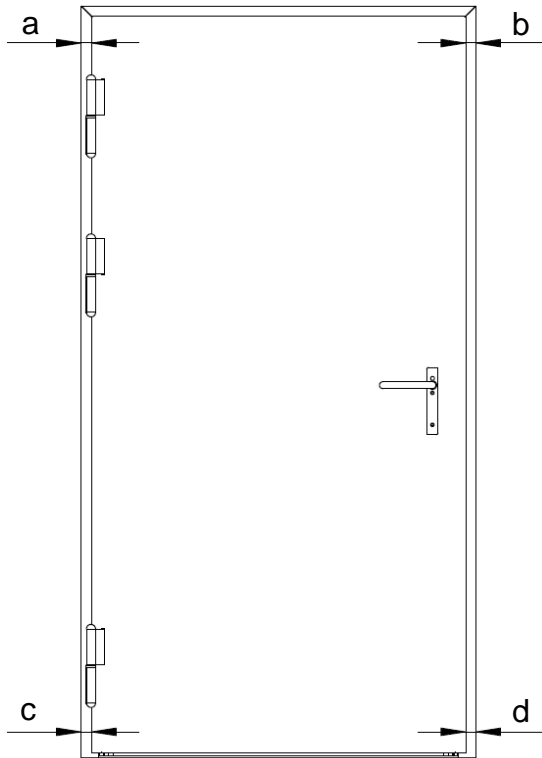

**Situation 1:  $a > b$**

Upper section of door leaf displaced inward

**Situation 2:  $a < b$**

Upper section of door leaf displaced outward

**Situation 3:  $c > d$**

Lower section of door leaf displaced inward

**Situation 4:  $c < d$**

Lower section of door leaf displaced outward

### 6.8.1 Type KOF 2-parts and 3-parts

1. Apply protective tape to the door hinges (see Figure 1).
2. If a third door hinge is present, remove the hinge bolt from the middle door hinge.
3. Place the hinge straightening tool onto the bottom part of the hinge and align the hinge position based on the respective situation.
4. Remove the hinge straightening tool and check the function and alignment of the door leaf again.
5. If the door rabbet collides with the frame after adjustment, the upper part of the respective hinge must be bent outward (see Figure 4).
6. Remove the hinge straightening tool and check the function and alignment of the door leaf again.
7. If a third door hinge is present, place the hinge straightening tool onto the lower part of the centre door hinge (frame section) and align the lower part of the hinge to the upper part of the hinge. Subsequently, replace the hinge bolt.
8. Remove the protective tape.

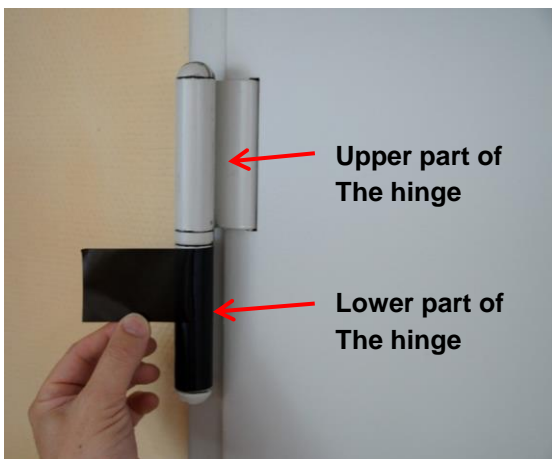

**Figure 1:** Apply protective tape



**Figure 2:** Bend the lower part of the hinge outward



**Figure 3:** Bend the lower part of the hinge inward



**Figure 4:** Bend the upper part of the hinge outward

**6.8.2 Type KOH-3D**

Height adjustment: turning the setscrew (M20) at the lower part of the hinge

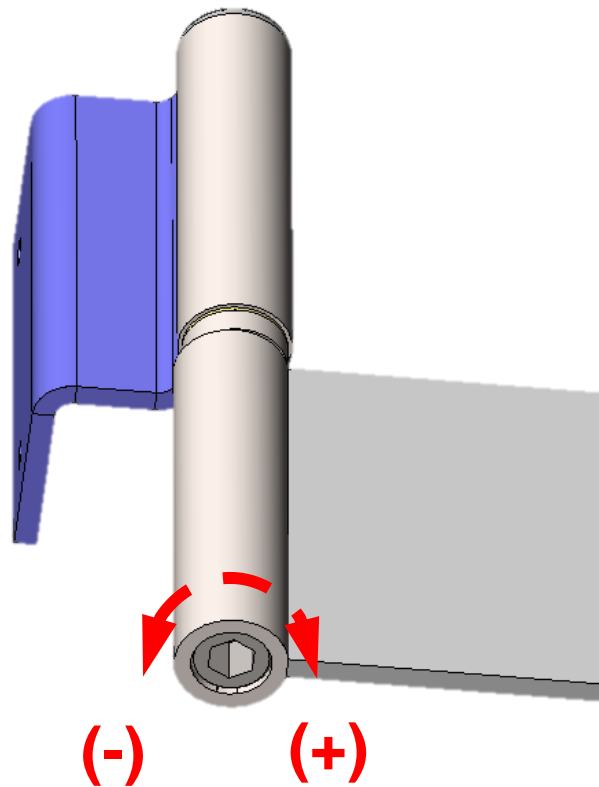

Lateral adjustment with eccentric tappet position of the hinge pin: turning the hinge pin to the left or to the right

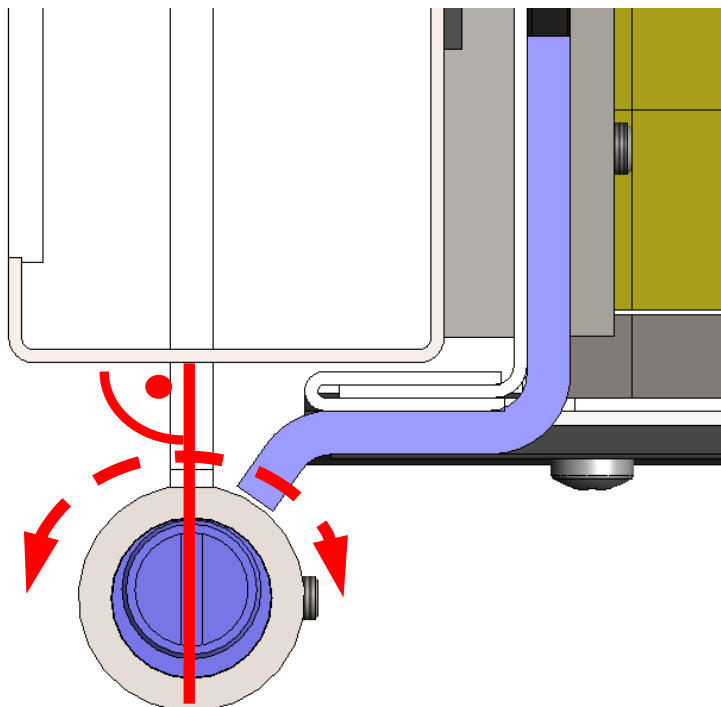

### 6.8.3 Typ 3D

#### Pressure / height adjustment

1. Open and secure the door leaf to 90°
2. Slightly loosen the clamping screws on the frame
3. Move the door leaf to the desired position
4. Tighten the clamping screws again
5. Remove wedges again, close door and check alignment

#### Lateral adjustment

1. Open the door leaf to 90°
2. Unscrew the cover plates
3. Loosen the locking setscrews
4. Turn the spindle screws on the door leaf in the appropriate direction (mini ratchet Allen key S5).
5. Close door and check alignment
6. Tighten the locking set screws and replace the cover plates



Adjust the spindle screws evenly. In case of uneven adjustment, stresses occur which can lead to damage of the threads.

Adjust the belts so that the belt axes are collinear with each other. Inadequate alignment may lead to increased bearing wear. Correct alignment guarantees that the belts run smoothly for a long time.



If the lateral adjustment is difficult to move, re-oiling the spindle screws can help.

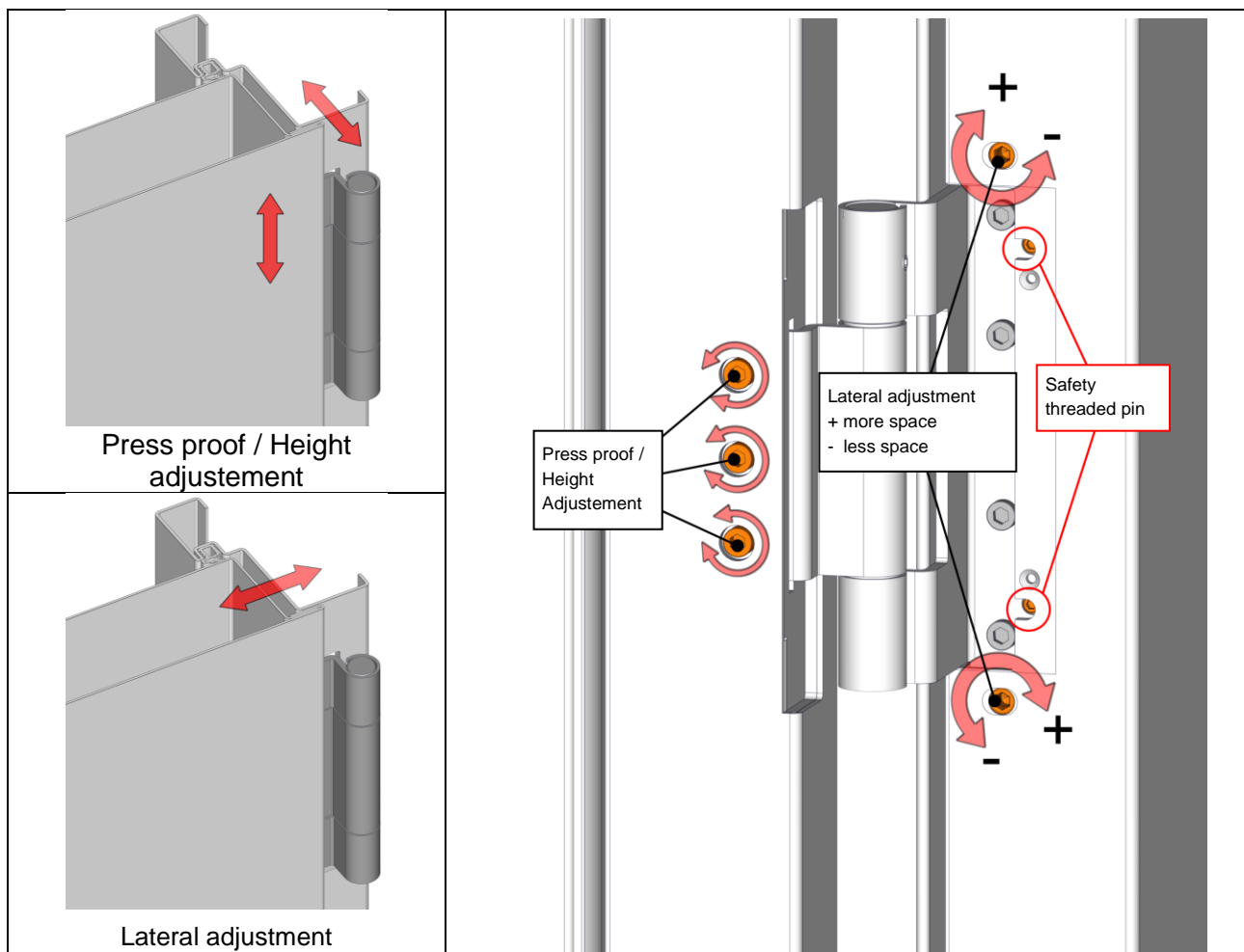

## 6.9 Frame grouting

If required by the application, the frame must be completely backfilled with mortar. The grouting can be done with a mortar machine or a hand-operated mortar syringe (hand pump). The mortar to be used can be ordered from the door manufacturer.



Wear protective gloves and goggles when working.

- Frame grouting mortar class M10 according to EN 998-2 (e.g. "Hilti CP 633")
- Absorbent substrates must be pre-watered (observe manufacturer's instructions).
- Seal or shutter the vertical gap on the opposite side. This prevents the mortar from flowing off uncontrolled.
- Mix frame grout according to manufacturer's instructions. The mortar should be just moist enough not to run away.
- Backfill the side frame parts completely with mortar from bottom to top. Knock off the frame parts with a rubber hammer to compact the mortar.
- Backfill upper frame part completely with mortar
- Smooth the joints between the frame profiles and the shell with a smoothing trowel and then wipe off the frame profiles with a clean sponge.
- After the mortar has begun to set, the waterproofing or formwork on the opposite side can be removed. Then smooth off the joint and wipe off the frame profiles with a clean sponge.
- To prevent corrosion, due to the corrosive properties of mortar, the frame and door leaf must be completely cleaned after grouting (see **Chapter 10.4**).

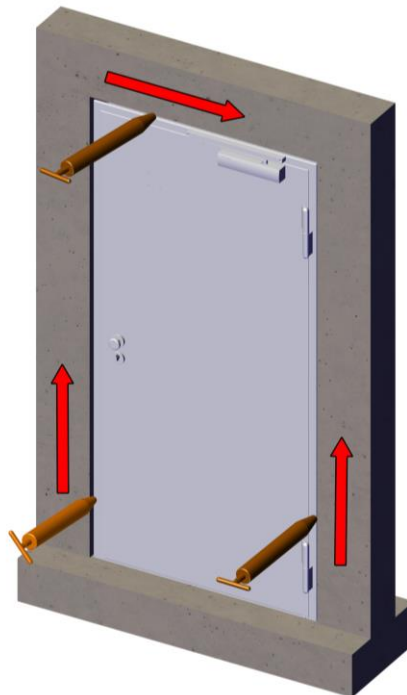



## 6.10 Special performance characteristics

### 6.10.1 Air tightness / Water tightness / Wind load resistance

The wall connection joints must be sealed on at least one side (weathering side = outside) with permanently elastic material (e.g. acrylic / silicone). If the frame is filled with foam or mortar, the joint of permanently elastic material can be omitted.

### 6.10.2 Sound protection

The following points must be observed for doors with sound insulation classification:

- The wall must have at least the same sound insulation value as the door.
- Backfill the frame with mineral mortar (e.g. class M10 according to EN 998-2 or higher). The procedure can be found in **Chapter 6.9**.

### 6.10.3 Burglary resistance

The following points must be observed for doors with burglar protection classification:

- Backfill the frame with mineral mortar (e.g. class M10 according to EN 998-2 or higher). The procedure can be found in **Chapter 6.9**.
- Securing of the tapes (only for KOF-hinges) by driving steel balls  $\varnothing$  3 mm into the threaded pins M5 of the tapes.

#### Permitted wall types:

Resistance class according to DIN EN 1627	Wall thickness (mm)			
	Masonry according to DIN 1053-1 or DIN EN 1996-1-1 Strength class $\geq$ 12 Mortar group II	Reinforced concrete according to DIN 1045 or DIN EN 1992-1-1 Strength class $\geq$ B15	Cellular concrete according to DIN EN 771-4 Compressive strength class $\geq$ 4	Light partition walls with resistance class verification
<b>RC-2</b>	$\geq$ 115	$\geq$ 100	$\geq$ 170	$\geq$ 100
<b>RC-3</b>	$\geq$ 115	$\geq$ 120	$\geq$ 240	$\geq$ 100
<b>RC-4</b>	$\geq$ 240	$\geq$ 140	-	-

#### Profile cylinder

For burglar-resistant doors/ security doors, the profile cylinders must correspond to the respective resistance class according to DIN 18252 or EN 1303 (see table NA.1). If the outer shield does not have a cylinder cover, the profile cylinder must be flush with the outer shield.

### 6.10.4 Smoke protection

The wall connection joints must be sealed on at least one side with permanently elastic material (e.g. acrylic / silicone). If the frame is filled with foam or mortar, the joint made of permanently elastic material can be omitted.

### 6.10.5 Fire protection

The following points must be observed for fire protection closures:

- Installation may only be carried out in/on the wall types listed below.

- For anchor fastening, only products with a general building supervisory approval or with a European Technical Approval may be used which are also suitable/approved for the respective anchor base.
- Installation in cellular concrete and mounting wall only possible with U-frame

### Underlay material

- For mortar backfilling steel and plastic possible
- For plaster only steel possible

### Backfill

The adhesive bond between frame and mortar does not have to be proven, so that it is harmless if the mortar detaches from the frame after setting. Blowholes/air inclusions are usually unavoidable. With professional backfilling, however, the formation of shrinkage cavities can be reduced as far as possible.

- Frames lined with plaster strips ("dry assembly") only permitted for wrap-around frames (not for 120 min. doors)
- Frames lined with plaster strips ("dry assembly") only permitted for wrap-around frames (not for 120 min. doors)

### Permitted wall types:

Fire resistance class according to EN 1634	Wall thickness (mm)			
	Masonry according to DIN 1053-1 or DIN EN 1996-1-1 Strength class $\geq$ 12 Mortar group II	Reinforced concrete according to DIN 1045 Strength class $\geq$ B15	Cellular concrete according to DIN EN 771-4 Compressive strength class $\geq$ 4	Light partition walls with resistance class verification
<b>EI<sub>2</sub> - 30</b>	$\geq$ 125	$\geq$ 100	$\geq$ 150	$\geq$ 100
<b>EI<sub>2</sub> - 90</b>	$\geq$ 175	$\geq$ 140	$\geq$ 150	$\geq$ 125
<b>EI<sub>2</sub> - 120</b>	$\geq$ 175	$\geq$ 175	-	-

### Profile cylinder

For fire doors, the profile cylinders must be non-combustible and have a melting temperature of  $> 840^{\circ}\text{C}$ .

## 6.11 Assembly of accessories

Depending on the order specification, various attachments are included with the system.

Only tested and approved fittings and profile cylinders may be installed.

**The use of non-standard replacement fittings and other components, as well as structural modifications to the door, leads to annulment of the respective serviceability certificate.**

### Door closer (required for closures with smoke protection and fire protection)

Door closers in accordance with EN 1154 are essential because they are part of the system for inquiring about and referring to the door manufacturer.

### Door coordinator (required for double-leaf closures with smoke protection and fire protection)

The door sequence selector controls the correct closing sequence of active and inactive door leaves in double-leaf designs. When using a closing sequence controller, a driver flap is required. It is mounted on the inactive leaf opposite the hinge side, and when the door is opened it has the task of opening the active leaf to a certain width, which is regulated by the closing sequence controller.

If this is not integrated into the door closer or the swing door drive, a separate closing sequence controller and driver flap are included in the delivery.

### Door handle

Door handles are indispensable for operating the door. These should be mounted on the door system according to the manufacturer's installation instructions.

### Locking mechanisms

For fire protection closures that should be open, the closure must be equipped with a suitable arrest system. The system must have general building inspectorate approval to prove its practicability.

## 6.12 Frame sealing obligatory for outdoor use

All elements that are not filled with mortar must be sealed.

Otherwise, joints up to a width of 15 mm must be sealed with a permanently elastic material.

In the following cases there is no permanently elastic sealing:

- For doors (burglar-proof, bullet-proof, fireproof), filler mortar is used.
- In the event of serious angle or flatness deviations of the walls or ceiling sides, a permanently elastic joint is not produced (according to the specifications of DIN 18202:2005 Table 2 - Limit values for angle deviations and Table 3 - Limit values for flatness deviations).

**Table 2 - Limit values for angular deviations**

Column	1	2	3	4	5	6	7	8
Line	Indication	Dimensions as limit values in mm for nominal dimensions in m						
		Up to 0,5	from 0,5 to 1	from 1 to 3	from 3 to 6	from 6 to 15	from 15 to 30	Superior to 30 <sup>a</sup>
1	Vertical, horizontal and inclined surfaces	3	6	8	12	16	20	30
<sup>a</sup> These limit deviations can be used for nominal dimensions up to approx. 60 m. For larger dimensions, special considerations are required.								

Dimension to determine the angular deviation

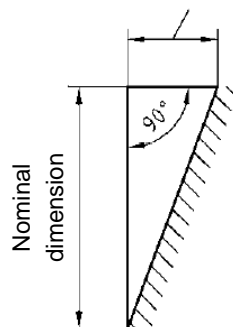

For example, for a wall height of up to 3 m, a maximum deviation of 8 mm can be allowed.

Table 3 - Limit values for flatness deviations

Column	1	2	3	4	5	6
Line	Indication	Dimensions as limit values in mm for intervals measured in m up to				
		0,1	1 <sup>a)</sup>	4 <sup>a)</sup>	10 <sup>a)</sup>	15 <sup>a)b)</sup>
1	Unfinished surface coatings for slabs, concrete foundations and concrete floors	10	15	20	25	15
2	Unfinished surface ceilings or floor slabs for fixing floor structures, e. g. composite or partition screeds, floating screeds, industrial floors, tiles and slabs in mortar beds Flat surfaces of ceilings or floor slabs for subordinate uses, e. g. in storage rooms, cellars, monolithic concrete floors.	5	8	12	15	20
3	Ready-to-use floors, e. g. screeds, floor coverings, floor coverings, tiles, slabs, filled and glued coverings, etc.	2	4	10	12	15
4	Like row 3, but with increased requirements, e. g. self-levelling masses.	1	3	9	12	15
5	The surfaces of the walls and ceilings	5	10	15	25	30
6	Ready-made walls and ceilings, e. g. plastered walls, wall coverings, false ceilings, etc.	3	5	10	0	25
7	Like line 6, but with increased requirements	2	3	8	15	20

<sup>a</sup> The intermediate values are shown in Figs. 5 and 6 and are rounded to the nearest whole mm

<sup>b</sup> The limit values for flatness deviation indicated in column 6 also apply to point measuring distances greater than 15 m.

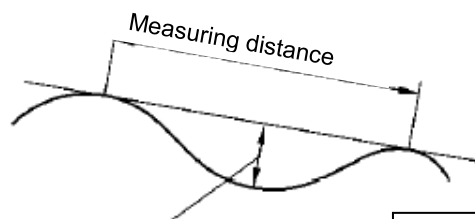

Dimension to determine the flatness deviation

For example, a maximum deviation of 10 mm may be present over a length of 1 m for walls that are not ready for surface finishing.

If adequate and appropriate sealing is required due to inadequate temperature or weather conditions are not possible, the sealing work must be carried out on site.

**At temperatures below 5°C and above 40°C on the wall surface, joints must not be made.**

If the grouting work deviates from the above-mentioned specifications or if grouting on the part of the customer is specified, grouting on the part of the customer shall be carried out.

#### Sealing compounds:

- Always use silicone or acrylic.
- The use of silicone is prohibited by car or paint booth manufacturers. Customer specifications must be taken into account (acrylic can be used inside).
- In the event of aggressive environmental influences, the use of suitable sealants must be checked and evaluated.

**Execution of the permanently elastic sealing:**

- Mask joint edges if necessary.
- The depth of the joint must be half the width of the joint. For  $\geq 5$  mm joints, a filling with a compriband joint (sealing joint), rock wool or an equivalent product must be carried out.
- In the case of mineral substrates, pre-treatment with primer may be necessary.
- Good contact with the joint flanks is to be established by pressing and smoothing, whereby as little as possible and only compatible smoothing agents are to be used.
- Non-fragile (nfb) joint sealants (sealants which are damaged by rain in their fresh, plastic state) must be protected from contact with water by suitable measures after application.
- Silicone joints are maintenance joints which are subject to regular visual inspection during annual maintenance. In case of poor joint condition, the operator will be informed. Joints are not reworked during the annual inspection.
- Relevant standards (DIN 18360 VOB Part C, DIN 18540 Sealing of external wall joints and DIN 18202 Tolerances in building construction) must be taken into account in the handling steps described.

## 7 Operation

### 7.1 Commissioning

The term "commissioning" refers to the first use of a system by the operator.

This may only take place if the system is fully assembled, tested and accepted by the operator.

The safety notes in **Chapter 4** apply for the commissioning of the system.

System sections can only be commissioned by qualified technical personnel.

Observe the following before commissioning the system:

- Inspect/check that no foreign objects (tools, materials, etc.) were left in the area of the system's movable parts after assembly.
- Ensure that rotating and linear moving parts can move freely in their designated space.
- Check the bearings for proper installation and lubrication.
- The fuse in the control cabinet is used to switch the supply voltages off and on.
- Check whether the operating voltage corresponds to the voltage indicated in the chart.
- To ensure that all mechanical and electrical components are tested, the attached test protocol must be processed before commissioning the system.

### 7.2 Decommissioning



Since the product is a safety-relevant system, it may only be decommissioned by suitably qualified and authorised persons. It is recommended if necessary, but the decision is up to the operator.

## 8 Maintenance and Servicing

### 8.1 General Information

The purpose of servicing tasks is to prevent door/gate system downtimes, increase service life, use in the best possible way and reduce failures.

The safety instructions described in **Chapter 4** apply to door/gate system servicing.



Only trained expert personnel are allowed to perform maintenance and repair work.

Access to the door/gate system is only allowed via designated pathways. Use a lifting platform when working at inaccessible heights.

Prepare and/or cordon off the working area to prevent injuries from falling material.

Only specialists or authorised individuals are allowed to perform complex repair work.

Check safety devices immediately after finishing maintenance work.

### 8.2 Servicing

The doors/gates and built-in components are subject to wear during operation. The task of servicing (maintenance, inspection and repair) is to maintain or restore the performance characteristics of the entire system.

"Safety through servicing" means that the door/gate will receive regular inspection, careful maintenance and conscientious repair, which are crucial for a usable and safe condition, and to retain the value of the system.

The doors/gates should be serviced at least once yearly to ensure permanently smooth operation of the plant.

Maintenance by the manufacturer is only available for clean doors/gates (including opening and close range). Cleaning of the doors can be done free required by the manufacturer. The operator has to take over the costs for additional expenditure of time possibly with additional breaks or costs for approach and hotel.

**A proof must be kept, to confirm that the necessary inspections have been carried out.**

For example, this can be an entry in a log book or by attaching an inspection report.

**It is strongly recommended to also entrust the manufacturer of the system with inspections or at least to consult him. The manufacturer offers the best guarantee that his trained professionals can carry out a proper assessment due to their exact knowledge of the design and the regulations to be.**

### 8.3 Monthly checks

The door/gate components have to be constantly kept ready for use. It must be checked at least every month for operational readiness by the operator, under his own responsibility.

This monthly check must be carried out by a qualified electrician or a person trained for this purpose. The results must be kept in a log book.

### 8.4 Yearly inspection and maintenance

For trouble-free operation of the door/gate system, the operator is also obliged to carry out an inspection at least once yearly and to perform maintenance (or have it done).

This yearly maintenance must be carried out by a qualified electrician or a person trained for this purpose. The results must be kept in a log book.

#### The following points must be especially observed:

- Mechanical and corrosion damage
- Trouble-free closing of the gate/door and a check for circulating air between the sash and frame
- Check moving parts for ease of movement
- If necessary tighten the mounting screws
- Check fittings for completeness and tight fit (refasten screws and/or replace fitting, if necessary)
- Check intumescent material for completeness and intactness.
- Check door/gate system rubber seals and leak-tightness
- Water damages
- Check all electrical fitting components such as proximity switches, etc.
- Check the state of cables, in particular the cable transition and the electrical plug-in connectors
- Damaged or missing parts; these must be replaced by original components and only approved by qualified persons

If the system is found to be damaged, and the damages cannot be rectified by the described measures, the manufacturer of the system must be informed immediately.

**It is very clearly indicated that any damage to the door/gate system affects its proper functioning and will void the manufacturer's product.**

The checklist for maintenance, commissioning and acceptance must be processed.

### 8.5 Safety regulations

The safety notes in **Chapter 4** apply for inspections and maintenance work on the door/gate system.



If possible, inspection and maintenance work should be carried out on a de-energized door/gate system. The area must be secured accordingly if work can only be carried out on an energized door/gate system. If the maintenance is neglected or carried out by unauthorised persons, the manufacturer cannot be held liable for damages and injuries.

Subsequent changes and modifications to the system may only be carried out by authorised service personnel, while taking into account the limits of application.

To ensure the availability of the door/gate system, parts subject to wear should be replaced preventively.



**Requirements for the operator**

During the planned maintenance period, the access routes must remain fully accessible.

The power supply and the lighting of the door/gate system in the affected maintenance section must be ensured.

When choosing the maintenance period, the operator must ensure that the maintenance works do not cause any obstruction.

In the course of maintenance, the door/gate system must be opened and closed several times for inspection purposes.

The entry is temporarily inaccessible during maintenance works.

**Requirements for the working personnel**

Maintenance work on the door/gate system may only be carried out by competent persons.

They are familiar with the relevant industrial safety regulations, accident prevention regulations, directives and generally accepted engineering standards to the extent that they can assess the safe condition of the door/gate system.

**Consequences of non-compliance**

If the servicing works on the systems and their components are not carried out as described and at the specified intervals, it may cause a decrease in availability, which, under certain circumstances, can hinder operation.

In this case the manufacturer declines all responsibility concerning functionality and safety.

The agreed warranty cannot be granted in this case.

## 8.6 Recommissioning

Upon completion of the inspection and maintenance work, the door/gate system must be recommissioned in the following sequence:

- Ensure that all components and/or components are mounted and wired properly.
- Ensure that all covers are closed and locked.
- Ensure that there no objects or tools are left behind in the door/gate system or in its vicinity.
- Ensure that the door/gate system can be unlocked and opened manually.
- Ensure that the door/gate system closes automatically and that the lock engages.

The maintained door/gate system is ready again for normal operation.

## 8.7 Checklist for maintenance, commissioning and acceptance

Maintenance    Gate test    Commissioning    Acceptance

Company, Location: \_\_\_\_\_ Fabrication-No.: \_\_\_\_\_ build year: \_\_\_\_\_

Gate Type: \_\_\_\_\_ Gate Labelling (by manufacturer): \_\_\_\_\_

n.o. = no objection - o. = objection

### Rolling Shutter Doors, Sectional Doors, Lift Away Shutter

#### Doors, etc.

- |   | n.o.                     | o.                       |
|---|--------------------------|--------------------------|
| <b>1. Shutter Curtain</b>   |                          |                          |
| 1.1 Slats resp. Grille _____  | <input type="checkbox"/> | <input type="checkbox"/> |
| 1.2 Lateral locking device, inside, left and right _____  | <input type="checkbox"/> | <input type="checkbox"/> |
| 1.3 Attachment of shutter curtain on the shaft _____  | <input type="checkbox"/> | <input type="checkbox"/> |
| 1.4 Attachment and condition of the consoles _____  | <input type="checkbox"/> | <input type="checkbox"/> |
| 1.5 Tracks, inlet moulds, plastic sliding inlets _____  | <input type="checkbox"/> | <input type="checkbox"/> |
| 1.6 shaft, storage _____  | <input type="checkbox"/> | <input type="checkbox"/> |
| 1.7 stays, rolls _____  | <input type="checkbox"/> | <input type="checkbox"/> |
| 1.8 wicket, locking with the drive _____  | <input type="checkbox"/> | <input type="checkbox"/> |
| <b>2. Drive</b>   |                          |                          |
| 2.1 Attachment of the physical drive and its consoles _____   | <input type="checkbox"/> | <input type="checkbox"/> |
| 2.2 Density of gear-box _____   | <input type="checkbox"/> | <input type="checkbox"/> |
| 2.3 Lubricant level _____   | <input type="checkbox"/> | <input type="checkbox"/> |
| 2.4 Retarding effect _____  | <input type="checkbox"/> | <input type="checkbox"/> |
| 2.5 Condition of electrical wires and connections _____   | <input type="checkbox"/> | <input type="checkbox"/> |
| 2.6 Drive chain, drive cable _____  | <input type="checkbox"/> | <input type="checkbox"/> |
| 2.7 Sprocket wheel protection _____   | <input type="checkbox"/> | <input type="checkbox"/> |
| 2.8 Manual operation device (Drive Switch Off) _____  | <input type="checkbox"/> | <input type="checkbox"/> |
| 2.9 Slowing-down path _____   | <input type="checkbox"/> | <input type="checkbox"/> |
| <b>3. Control</b>   |                          |                          |
| 3.1 Control switches, push buttons, key switches _____  | <input type="checkbox"/> | <input type="checkbox"/> |
| 3.2 End switch _____  | <input type="checkbox"/> | <input type="checkbox"/> |
| 3.3 Emergency end switch _____  | <input type="checkbox"/> | <input type="checkbox"/> |
| 3.4 Engine protection switch _____  | <input type="checkbox"/> | <input type="checkbox"/> |
| 3.5 Main switch or plug connection (required) _____   | <input type="checkbox"/> | <input type="checkbox"/> |
| 3.6 Devices in connection with remote control, e.g. Emergency Off-Switch, Emergency Off-Main Switch _____   | <input type="checkbox"/> | <input type="checkbox"/> |
| <b>4. Protection mechanisms against squeezing and shearing</b>  |                          |                          |
| 4.1 Contact ledges at the closing edges _____   | <input type="checkbox"/> | <input type="checkbox"/> |
| 4.2 Remote control (e.g. automatic closing, radar, radio) however in connection with light beams only _____ | <input type="checkbox"/> | <input type="checkbox"/> |
| 4.3 Monitoring of closing area, e.g. light beams _____  | <input type="checkbox"/> | <input type="checkbox"/> |
| <b>5. Protection against Shutter Curtain Collision</b>  |                          |                          |
| 5.1 Catch devices _____   | <input type="checkbox"/> | <input type="checkbox"/> |
| 5.2 Attachments, lock controls (handles) _____  | <input type="checkbox"/> | <input type="checkbox"/> |
| 5.3 Flexible Spindle _____  | <input type="checkbox"/> | <input type="checkbox"/> |
| <b>6. Labelling</b>   |                          |                          |
| 6.1 Manufacturer or Supplier, Construction Year, Fabrication-No. _____                                      | <input type="checkbox"/> | <input type="checkbox"/> |

### Doors, Gates, Sliding Doors, Folding Shutter Doors, etc.

- |  | n.o.                     | o.                       |
|--|--------------------------|--------------------------|
| <b>1. Leaves and Guide ways</b>  |                          |                          |
| 1.1 Leaves and leave inlets _____  | <input type="checkbox"/> | <input type="checkbox"/> |
| 1.2 Closing edges, sealings _____  | <input type="checkbox"/> | <input type="checkbox"/> |
| 1.3 Guide ways, tracks (fixed stops) _____   | <input type="checkbox"/> | <input type="checkbox"/> |
| 1.4 Rollers, multiplying-lever extensometer, hinges _____  | <input type="checkbox"/> | <input type="checkbox"/> |
| 1.5 Attachment of the leaves, Protection against collision _____   | <input type="checkbox"/> | <input type="checkbox"/> |
| 1.6 Wicket, locking with the drive _____   | <input type="checkbox"/> | <input type="checkbox"/> |
| <b>2. Drive</b>  |                          |                          |
| 2.1 Attachment of the physical drive and its consoles _____  | <input type="checkbox"/> | <input type="checkbox"/> |
| 2.2 Density of gear-box _____  | <input type="checkbox"/> | <input type="checkbox"/> |
| 2.3 Lubricant level _____  | <input type="checkbox"/> | <input type="checkbox"/> |
| 2.4 Retarding effect _____   | <input type="checkbox"/> | <input type="checkbox"/> |
| 2.5 Condition of electrical wires and connections _____  | <input type="checkbox"/> | <input type="checkbox"/> |
| 2.6 Drive-chain, drive cable _____   | <input type="checkbox"/> | <input type="checkbox"/> |
| 2.7 Sprocket wheel protection _____  | <input type="checkbox"/> | <input type="checkbox"/> |
| 2.8 Manual Operation Device (Drive Switch-Off) _____   | <input type="checkbox"/> | <input type="checkbox"/> |
| 2.9 Overload protection (slipper clutch, relief pressure valves, overflow valves) _____                      | <input type="checkbox"/> | <input type="checkbox"/> |
| 2.10 Slowing-down path _____   | <input type="checkbox"/> | <input type="checkbox"/> |
| <b>3. Control (not in connection with locking mechanisms)</b>  |                          |                          |
| 3.1 Control switches, push buttons, key switches _____   | <input type="checkbox"/> | <input type="checkbox"/> |
| 3.2 End switch _____   | <input type="checkbox"/> | <input type="checkbox"/> |
| 3.3 Emergency end switch _____   | <input type="checkbox"/> | <input type="checkbox"/> |
| 3.4 Engine protection switch _____   | <input type="checkbox"/> | <input type="checkbox"/> |
| 3.5 Main switch or plug connection (required) _____  | <input type="checkbox"/> | <input type="checkbox"/> |
| 3.6 Devices in connection with remote control, e.g. Emergency Off-Switch, Emergency Off-Main Switch _____    | <input type="checkbox"/> | <input type="checkbox"/> |
| <b>4. Protection mechanisms against squeezing and shearing</b>   |                          |                          |
| 4.1 Contact ledges at the closing edges _____  | <input type="checkbox"/> | <input type="checkbox"/> |
| 4.2 Remote control (e.g. automatic closing, radar, radio), however in connection with light beams only _____ | <input type="checkbox"/> | <input type="checkbox"/> |
| 4.3 Monitoring of closing area, e.g. light beams _____   | <input type="checkbox"/> | <input type="checkbox"/> |
| 4.4 Contact mats _____   | <input type="checkbox"/> | <input type="checkbox"/> |
| 4.5 Safety zone between leaves and fixed parts in the surrounding area _____                                 | <input type="checkbox"/> | <input type="checkbox"/> |
| <b>5. Labelling</b>  |                          |                          |
| 5.1 Manufacturer or Supplier, Construction Year, Fabrication-No. _____                                       | <input type="checkbox"/> | <input type="checkbox"/> |

### Locking Mechanisms

- |  |                          |                          |  |                          |                          |
|--|--------------------------|--------------------------|--|--------------------------|--------------------------|
| <b>1. Function Test</b>  |                          |                          | <b>2. Control</b>  |                          |                          |
| 1.1 Closing devices, e.g. door closer, spring cable pulley _____     | <input type="checkbox"/> | <input type="checkbox"/> | 2.1 Controls, push buttons _____                                     | <input type="checkbox"/> | <input type="checkbox"/> |
| 1.2 Installation, function and number of fire detectors _____        | <input type="checkbox"/> | <input type="checkbox"/> | 2.2 Control unit _____   | <input type="checkbox"/> | <input type="checkbox"/> |
| 1.3 Adhesive magnets, magnetic valves, magnetic clutches _____       | <input type="checkbox"/> | <input type="checkbox"/> | 2.3 Control devices _____  | <input type="checkbox"/> | <input type="checkbox"/> |
| 1.4 Closing area – labelling, fender _____                           | <input type="checkbox"/> | <input type="checkbox"/> | 2.4 Energy supply (power supply voltage, battery voltage) _____      | <input type="checkbox"/> | <input type="checkbox"/> |
| 1.5 Approval label available as control sign _____                   | <input type="checkbox"/> | <input type="checkbox"/> | 2.5 Condition of electrical wires, connections and attachments _____ | <input type="checkbox"/> | <input type="checkbox"/> |
| 1.6 Door closes from any opening angle (closing time 4-7 sec.) _____ | <input type="checkbox"/> | <input type="checkbox"/> |  |                          |                          |

Label Maintenance and/or Locking Mechanism attached _____	Yes <input type="checkbox"/>	No <input type="checkbox"/>
Facility according to ASR 1.7 EN12453 _____	Yes <input type="checkbox"/>	No <input type="checkbox"/>
Report of operating powers measurement attached _____	Yes <input type="checkbox"/>	No <input type="checkbox"/>
Operating Powers measurement okay _____	Yes <input type="checkbox"/>	No <input type="checkbox"/>
Decline shield of locking mechanisms available _____	Yes <input type="checkbox"/>	No <input type="checkbox"/>

Comments: \_\_\_\_\_

Next Check: \_\_\_\_\_ Date: \_\_\_\_\_ Signature Examiner: \_\_\_\_\_ Signature Operator: \_\_\_\_\_

## 9 Troubleshooting

Fault symptom	Possible cause	Fault rectification
Door does not close automatically	Door closer	Adjust door closer
Door cannot be completely closed	Lock	Check that the lock recesses are free of dirt and foreign objects
	Closure sequence	First the inactive leaf, then the active leaf
	Objects in the door area	Remove objects
Door opens/closes stiffly	Retractable floor seal sticks in lowered position	Clean retractable floor seal or if necessary replace it with a new one
Retractable floor seal does not lower	Dirty or defective	Clean retractable floor seal, adjust the triggering device or if necessary replace it with a new one

## 10 Cleaning and care instructions

### 10.1 General information

The object and purpose of these cleaning instructions is to provide the operating and cleaning personnel with helpful information regarding the care and cleaning of the door systems.

Besides proper handling, even regular cleaning and care are a prerequisite for maintaining the service life and functionality of the systems.

This is the only way to ensure corrosion resistance and operational integrity.

A thorough cleaning should be performed annually. In case of heavy soiling or contamination, it is recommended to shorten the cleaning intervals accordingly.

The operator is responsible for cleaning.

In tunnels strong dirt deposits are possible in the area of inclines or declines, which considerably restrict the functionality of doors.

If the cleaning agents used are not the ones mentioned in this manual, the system operator takes full responsibility of the consequences.

**The surface must be rinsed with clean water after cleaning.**

### 10.2 Steel

The following section indicates unsuitable and suitable cleaning products and other suitable aids.

If no information is given in the cleaning instructions about special cleaning techniques and cleaning products for the various components of the door system, then you should use the list of cleaning products in this section as a guideline.



#### Unsuitable cleaning products:

- Media containing hydrochloric or hydrofluoric acid
- Abrasive material
- Furniture polishing products and other so-called "polishers"
- Products containing chloride
- Bleaching agents
- Acidic cleaning products



#### Suitable cleaning products:

- Standard cleaning products (manufacturer's instructions for their use must be observed)
- Alkaline cleaning products (use soft polishing cloth)

### 10.3 Stainless steel

Stainless steels - also known as stainless steel - are much more resistant to corrosion than many other metallic construction materials.

The reason for this is that the chemical composition of the steels forms a protective film on the surface, which is repeatedly rebuilt as a "passive layer" under the influence of oxygen. In practice, the corrosion load is determined by the attack media present and their intensity. The use of cleaning agents for basic and maintenance cleaning can also lead to aggressive stresses on construction and equipment parts.

The selection of the correct material is the responsibility of the customer/operator. Further information can be obtained, for example, from the Stainless Steel Association (ISER).

### Damage caused by flash rust

The term "rust film" describes fine iron dusts that rust in the air and precipitate on elements. If door elements come into contact with such "rust particles" or other rusting material, corrosion occurs.

As the process progresses, so-called "surface corrosion" and rust spots occur; the stainless steel surface begins to rust.

In any case, rust film or other deposits (dirt, foreign particles) must be removed from the door surfaces as quickly as possible in order to avoid further corrosion damage.

When installing the doors, it is important to pay attention to the immediate surroundings and the installation activities, which can cause visible rust formation.

### Cleaning of corrosion-resistant steels

Suitable cleaning and care products should be used to clean stainless steel. Aggressive cleaning agents should be avoided in any case, as they attack the protective passivating chromium oxide layer.

Stainless steel should always be kept clean. Dirt on the surface can trigger chemical reactions which can attack the passive layer of the stainless steel over time. As a result, the corrosion resistance of even high-quality stainless steels is lost over time. In areas which are more frequently exposed to dirt, cleaning must also be carried out more frequently.

Further information on cleaning stainless steel can be found in the document: Data sheet 824: "Cleaning stainless steel" by ISER.

In the following, unsuitable and suitable cleaners as well as suitable aids are mentioned.

If the cleaning instructions do not explicitly refer to special cleaning techniques and cleaners for the various components of the door/gate system, the cleaning agents listed in this section are binding.



#### Unsuitable cleaners:

- Media containing hydrochloric or hydrofluoric acid
- Abrasive material
- Materials made of carbon steel
- Chrome, silver, brass care products
- Furniture polishing products and other so-called "Polishers"
- Products containing chloride
- Bleaching agents
- Chemical cement remover



The use of hydrochloric acid detergents destroys the "passive layer" on stainless steel. This works against the corrosion resistance.



#### Suitable cleaners:

- All-purpose cleaners
- Neutral cleaners
- Alkaline cleaners (use soft polishing cloth)
- Acid cleaners (free of hydrochloric and hydrofluoric acid)



When cleaning, always follow the instructions and regulations regarding safety at work and environmental protection.



#### Suitable cleaning aids:

- Damp cloth or chamois

### Cleaning agents, in detail:

To remove **fingerprints**, it is generally enough if you use a soapy solution. To clean the stainless steel element, it is generally enough to rub it vigorously with a soft clean cloth, moistened with warm water with added all-purpose cleaner or neutral cleaning agent.

**Stubborn stains** can be removed with household scouring cream, which is also good against lime scale and slight discolorations. The surface must be rinsed with clean water after cleaning. A final rinse with distilled water prevents the formation of lime scale after drying. The surface is then wiped dry. For the subsequent regeneration phase of the "passive layer", the surface must remain dry and the surrounding air should not be humid. Scouring powders are unsuitable as they scratch the surface!

**Severe oil and grease marks** can be removed with alcohol cleaning agents and solvents, e.g. methylated spirit or acetone, which are safe for stainless steel surfaces. When doing so, it should be ensured that the undissolved contaminants are not spread out on the surface by the cleaning process. Cleaning must therefore be repeated with another clean cloth until all residues are removed.

**Traces of paint and graffiti** can be removed with special alkaline and solvent-based cleaners. Otherwise you can use turpentine or nitro thinner for cleaning. However, these may only be used on unpainted stainless steel, as they will damage the paint.

**Severely neglected surfaces** can be treated with polish, such as chrome care products for cars, but this must be carried out with care, as these can scratch.

## 10.4 Initial on-site cleaning

Any protective film should be completely removed immediately after installation and at the latest within one month, as otherwise corrosion may occur. The protective films are not permanently resistant to UV radiation and will be difficult to remove if left for a long time. This increases the risk that adhesive residue remains on the surface. When removing protective film, always proceed from top to bottom.

With stainless steel doors it is important that the surface must remain completely clean first, otherwise this "passive layer" cannot form properly under the influence of oxygen.

### Paint splashes

Paint splashes must be removed with solvent cleaner (e.g. turpentine, nitro thinner, trichloroethane, toluene).

### Lime or cement mortar splashes

Such contamination must be scraped off with a rubber spatula, a wooden spatula or the like before it hardens. Under no circumstances should you use any tools made of normal steel. To remove the last traces of lime and cement, you can use an acidic cleaner (free of hydrochloric and hydrofluoric acid). The door must be then rinsed off with plenty of clean water.



Under no circumstances should you use any tools made of rusting steel (e.g. trowels or steel wool).

### Iron particles / grinding dust / chippings / welding spatter



Iron particles from tools, scaffoldings and transport equipment must be removed immediately. Construction steel grade grinding dust, chippings and welding spatter tend to rust very quickly if they come into contact with stainless steel surfaces. They can penetrate through the passive layer of the stainless steel and cause pitting corrosion.

## 10.5 Glazing

### 10.5.1 Inspection

The frequency of inspections depends on the installation situation. We recommend the following inspection intervals depending on the installation situation:

- Doors in emergency exit routes and public buildings: every 3 months
- For glazing in buildings with normal use: every 6 months

#### The following must be observed:

- Inspection of the glass elements for damage (seepage / cracks)
- Check glazing seals
- Check glazing beads for proper fit

In the case of insulated glass, at certain angles of sunlight rainbows can become visible on flat and parallel glass panes (interference phenomena). This physical phenomenon is not a quality defect and is therefore not grounds for complaint.

Defects must be rectified immediately by a qualified professional.

Defective parts may only be replaced with original parts and by a qualified professional.

If damaged panes of glass are replaced, it must be ensured that the replacement panes comply with the provisions covering general building inspectorate approval.

### 10.5.2 Maintenance and care

The seals around the door should be regularly cleaned of dust and other deposits.

If a seal has come loose from the retaining groove, use your thumbs to press it back into position, starting at the fixed part. Do not use sharp objects.

### 10.5.3 Cleaning

Dirt on the glass panes can be removed with a soft sponge, cloth or plastic spatula and plenty of warm, soapy water. Sealant residues and grease can be removed with non-aggressive solvents, such as methylated spirits or isopropanol. Cleaning utensils and liquids must be changed frequently to ensure that washed-away dirt does not scratch the surface of the glass. Alkaline building materials such as cement and lime mortar must be immediately washed off with plenty of water before they harden.



#### Unsuitable cleaning products:

- Abrasive cleaning products (with scouring or abrasive constituents)
- Metal objects, such as steel wool, razor blades or steel spatulas



#### Suitable cleaning products:

- Soap and water
- Commercial spray-cleaning products (manufacturer's instructions must be observed)
- Non-aggressive solvents e.g. methylated spirits or isopropanol

## 10.6 Louvre grid

### 10.6.1 Maintenance and care

To ensure the airing function of the door foreign objects has to be removed regularly from the wire grating and the lamellae.

### 10.6.2 Cleaning

See also **chapter 10.1, 10.2 and 10.3**

## 10.7 Fittings, locks

It is recommended that all fittings are fully cleaned and checked for damage once a year.

If any damage is discovered in the lock or fitting area, the affected components must be replaced immediately.

## 10.8 Seals

When cleaning, it is necessary to check the condition of the seals for damage, brittleness and resetting behaviour. In the event of abnormalities, the seal must be replaced.



#### **Unsuitable cleaning products:**

- Grease spray
- Silicone



#### **Suitable cleaning products:**

- Cleaning agents and scrubbing brush
- Plastic intensive care product (only for silicone seals)



## 11 Replacement parts / Special tools

The replacement parts, repair guide and special tools can be acquired from the customer service department of Hodapp GmbH & Co. KG.

Please request them if needed.

E-Mail : [service@hodapp.de](mailto:service@hodapp.de)

Tel.: +49 7841 6006 600

For quick processing of your spare parts order or to answer questions and reply to incident reports, we need the following information:

- **Installation location of the system**
- **Year of manufacture**
- **Production number on the nameplate**
- **Description of fault**
- **Pictures**

## 12 Certificate of compliance

Product: **HoSta-1 / HoSta-2**

Building project: \_\_\_\_\_  
\_\_\_\_\_  
\_\_\_\_\_

Order/door position: \_\_\_\_\_

Installation company: \_\_\_\_\_  
\_\_\_\_\_  
\_\_\_\_\_

Installer: \_\_\_\_\_

Installed on: \_\_\_\_\_

It is hereby confirmed that the construction product has been installed professionally with regard to all details and in compliance with all provisions of the present installation, operation and maintenance instructions.

\_\_\_\_\_  
(Place, Date)

\_\_\_\_\_  
(Signature)

### **13 Remarks**

---

---

---

---

---

---

---

---

---

---

---

---

---

---

---

---

---

---

---

---

---

---

---

---

---

---

---



[www.hodapp.de](http://www.hodapp.de)  
[info@hodapp.de](mailto:info@hodapp.de)

Hodapp GmbH & Co. KG  
Grossweierer Strasse 77  
D-77855 Achern  
Germany  
Tel.: +49 (7841) 6006-0  
Fax: +49 (7841) 6006-10